



## Order confirmation

Open the package and check that the product conforms to your order. If any problem or inconsistency is found, immediately contact your distributor.

### a. Check if the delivery is correct.

Check the nameplate to see if the information such as model codes, discharge capacity, discharge pressure and power voltage are as ordered.

<b>Iwaki Metering Pump</b> 	
MODEL	
PRESSURE	PSI
CAPACITY	GPH
VOLTAGE	V
CURRENT	A
FREQUENCY	Hz
MFG.No.	
Year :	 <b>PM16-2</b>
Thermally Protected	<b>IP65</b>
Acceptable for indoor use only	
Enclosure type 2	
Utilisation intérieure uniquement	
Boîtier de type 2	<b>US</b>
Nonsubmersible Pump	<b>Intertek</b>
Conforms to UL Std.778	3111781
Certified to	
CAN/CSA Std.C22.2 No.108	1P425396

### b. Check if the delivery is damaged or deformed.

Check for transit damage and loose bolts.

# Contents

Order confirmation .....	2
<b>Safety instructions .....</b>	<b>6</b>
Warning.....	7
Caution.....	9
Precautions for use .....	13
<b>Overview.....</b>	<b>17</b>
<b>Introduction.....</b>	<b>17</b>
Pump structure & Operating principle .....	17
Features.....	19
Operational functions.....	19
<b>Part names.....</b>	<b>24</b>
Pump.....	24
Operational panel .....	25
Basic displays & Pump states .....	26
<b>Identification codes.....</b>	<b>28</b>
Pump/Drive units .....	28
<b>Installation .....</b>	<b>30</b>
<b>Pump mounting.....</b>	<b>30</b>
<b>Pipework .....</b>	<b>31</b>
Tube connection .....	31
Check valve mounting .....	33
<b>Wiring.....</b>	<b>35</b>
Power voltage/Earthing .....	35
Signal wire connection .....	37
Connections .....	39

<b>Before operation.....</b>	<b>42</b>
Points to be checked .....	42
Retightening of pump head fixing bolts .....	42
Use of hexagon wrench instead of a torque wrench .....	43
Degassing.....	43
Flow rate adjustment .....	46
Stroke rate adjustment .....	47
Stroke length adjustment.....	49
Before a long period of stoppage (One month or more).....	50
<b>Operation programming .....</b>	<b>51</b>
Programming flow.....	52
Manual operation.....	54
EXT operation.....	55
EXT mode .....	55
EXT mode programming.....	56
User mode .....	65
STOP/Pre-STOP function .....	66
STOP/Pre-STOP function cancellation.....	68
OUTPUT function.....	70
ANA-V/-R selection .....	72
Buffer ON/OFF selection.....	74
PIN number entry .....	76
Keypad lock .....	78
Keypad lock activation.....	79
Keypad lock release .....	79
Calibration mode .....	80
Unit change.....	81
spm indication.....	81

<b>Troubleshooting.....</b>	<b>83</b>
<b>Inspection.....</b>	<b>85</b>
Daily inspection .....	85
Periodic inspection .....	85
<b>Wear part replacement.....</b>	<b>86</b>
Wear part list.....	86
Before replacement .....	87
Valve set replacement .....	87
Discharge valve set dismantlement/assembly .....	87
Suction valve set dismantlement/assembly .....	89
Spacer set replacement (Auto degassing type) .....	90
Air vent valve set replacement (Auto degassing type) .....	91
Diaphragm replacement .....	91
<b>Exploded view.....</b>	<b>94</b>
Pump head, Drive unit & Control unit .....	94
Pump head .....	95
EWN-[B09•B11•B16•B21•C16•C21] [VC•VH•VE•PC•PH•PE•TC] .....	95
EWN-[B31•C31•C36] [VC•VH•VE•PC•PH•PE•TC] .....	96
EWN FC .....	97
EWN-C31 P6-V .....	98
EWN SH/SH-H/SH-H2.....	99
EWN with an Automatic air vent.....	100
<b>Specifications/ Outer dimensions .....</b>	<b>101</b>
Specifications .....	101
Pump unit .....	101
Power cable.....	103
Pump colour .....	103
Outer dimensions.....	104

# Safety instructions

**Read through this section before use. This section describes important information for you to prevent personal injury or property damage.**

## ■ Symbols

In this instruction manual, the degree of risk caused by incorrect use is noted with the following symbols. Please pay attention to the information associated with the symbols.



### **WARNING**

Indicates mishandling could lead to a fatal or serious accident.



### **CAUTION**

Indicates mishandling could lead to personal injury or property damage.

A symbol accompanies each precaution, suggesting the use of "Caution", "Prohibited actions" or specific "Requirements".

#### Caution marks



Caution



Electrical shock

#### Prohibited mark



Prohibited



Do not rework or alter

#### Requirement mark



Requirement



Wear protection



Grounding



## **Export restrictions**

Technical information contained in this instruction manual might be treated as controlled technology in your countries, due to agreements in international regime for export control.

Please be reminded that export license/permission could be required when this manual is provided, due to export control regulations of your country.

 **WARNING**
**Turn off power before service**

Risk of electrical shock. Be sure to turn off power to stop the pump and related devices before service is performed.

**Couper l'alimentation électrique de la pompe avant intervention**

Intervenir sur la pompe sans avoir au préalable coupé l'alimentation électrique peut déclencher des décharges électriques. Avant d'entreprendre n'importe quel type d'intervention, veuillez à mettre la pompe et tout dispositif connexe hors tension à l'aide de l'interrupteur prévu à cet effet.

**Stop operation**

If you notice any abnormal or dangerous conditions, suspend operation immediately and inspect/solve problems.

**Arrêter le fonctionnement**

Si vous détectez une anomalie ou des signes suspects et inhabituels pendant le fonctionnement, interrompez immédiatement les opérations et inspectez, résolvez les problèmes.

**Do not use the pump in any condition other than its intended purpose**

The use of the pump in any conditions other than those clearly specified may result in failure or injury. Use this product in specified conditions only.

**Se conformer uniquement aux applications prévues**

La pompe doit être utilisée conformément à l'usage pour lequel elle a été prévue et dans le respect de ses caractéristiques techniques. Toute utilisation non conforme peut entraîner un incident ou endommager le dispositif.

**Do not modify the pump**

Alterations to the pump carries a high degree of risk. It is not the manufacturer's responsibility for any failure or injury resulting from alterations to the pump.

**Ne pas modifier la pompe**

Ne jamais modifier une pompe sous peine de causer un incident grave. Iwaki ne pourra en aucun cas être tenu responsable d'un incident ou de dégâts survenus à la suite d'une modification du dispositif.



---

### **Wear protective clothing**

Always wear protective clothing such as an eye protection, chemical resistant gloves, a mask and a face shield during disassembly, assembly or maintenance work. The specific solution will dictate the degree of protection. Refer to MSDS precautions from the solution supplier.



### **Porter un équipement de protection**

Toujours porter un équipement de protection (lunettes, gants résistants aux produits chimiques, masque, casque) durant le démontage, l'assemblage et la maintenance.

Le travail effectué dictera le degré de protection. Référez-vous au MSDS de la solution proposée par le fournisseur.

---

### **Do not damage the power cable**

Do not pull, knot, or crush the power cable. Damage to the power cable could lead to a fire or electrical shock if cut or broken.

### **Ne pas endommager le câble électrique**

Ne pas tirer ou faire un nœud avec le câble électrique. Endommager un câble électrique peut provoquer une incendie ou une décharge électrique.



---

### **Do not operate the pump in a flammable atmosphere**

Do not place explosive or flammable material near the pump.

### **Ne pas utiliser la pompe dans une atmosphère explosive**

Pour votre sécurité, du matériel dangereux ou inflammable ne doit pas être placé près de la pompe.



---

### **Risk of electric shock**

This pump is supplied with a grounding conductor and grounding-type attachment plug. To reduce the risk of electric shock, be certain that it is connected only to a properly grounded, grounding type receptacle.

### **Risque de choc électrique**

La pompe est fournie avec un conducteur pour mise à la terre et une prise courant. Afin de réduire le risque de choc électrique, veillez à ce que la terre soit correctement raccordée.



**! CAUTION****Qualified personnel only**

The pump should be handled or operated by qualified personnel with a full understanding of the pump. Any person not familiar with the product should not take part in the operation or maintenance of the pump.



Requirement

**Opérateur qualifié uniquement**

La pompe doit être manipulée ou utilisée par du personnel qualifié connaissant parfaitement la pompe. Tout autre personne étrangère ne doit pas prendre part à l'utilisation ou à la maintenance de la pompe.

**Use specified power only**

Do not apply power other than that specified on the nameplate. Otherwise, failure or fire may result. Ensure the pump is properly grounded.



Prohibited

**Utilisez une tension appropriée uniquement**

Ne pas appliquer une autre tension que celle spécifiée sur la plaque signalétique sinon, il peut en résulter une panne ou un incendie. Assurez-vous également de la mise à la terre de la pompe.

**Do not run pump dry**

Do not run pump dry for more than 30 minutes (even when the pump runs for degassing). Otherwise, the pump head fixing screws may loosen and liquid may leak. Optimise your system. If the pump runs dry for a long period (for more than 30 minutes), the pump head and the valve cases may deform by friction heat and consequently leakage results.



Caution

**Ne faite pas fonctionner la pompe à sec**

Ne faite pas fonctionner la pompe à sec plus de 30 minutes (même lorsque la pompe fonctionne pour dégazer). Sinon, les visse de fixation de la tête peuvent se dévisser et il peut y avoir une fuite de liquide. Optimalisez l'installation de façon à ce que la pompe ne fonctionne pas à sec. Si la pompe fonctionne à sec pour une longue période (plus de 30 minutes), la tête de la pompe et le guide de clapets peuvent être déformés par friction causée par la chaleur et il en résulterait des fuites.



---

### Keep electric parts and wiring dry

Risk of fire or electric shock. Install the pump where it can be kept dry.

### Ne mouillez pas les parties électriques ou les câbles

Risque d'incendie ou de décharge électrique. Installez la pompe dans un endroit sec.



Prohibited

---

### Observe an applicable MSDS

Take account of installation environment. Chemicals should be controlled in accordance with a MSDS. Do not send potable water or circulate heated water with this pump.

### Observez un « MSDS » applicable

Tenez compte de l'environnement. Les produits chimiques doivent être surveillés en accord avec un MSDS. Ne pas utiliser cette pompe avec de l'eau potable ou de l'eau chaude.



Caution

---

### Do not install or store the pump:

- In a flammable atmosphere.
- In a dusty/humid environment.
- Where ambient temperature can exceed 0-40°C.
- In direct sunlight or wind & rain.

### N'installez ou ne stockez pas la pompe dans les endroits suivantes:

- Dans une atmosphère inflammable
- Dans un endroit poussiéreux ou humide.
- Dans une place où la température n'est pas comprise entre 0 et 40 °C.
- Directement sous le soleil, le vent ou la pluie.



Prohibited

---

### Spill precautions

Ensure protection and containment of solution in the event of plumbing or pump damage (secondary containment).

### Déversement accidentel

Prenez des mesures protectrices contre tout incident résultant d'un débit trop important de la pompe ou d'une casse de tuyauterie.



Requirement

---

**Do not use the pump in a wet location**

The pump is not waterproof. Use of the pump in wet or extremely humid locations could lead to electric shock or short circuit.



Prohibited

**N'utilisez pas la pompe sous l'eau**

La pompe n'est pas complètement étanche. Utiliser la pompe dans l'eau ou dans un endroit très humide peut créer une décharge électrique ou un court-circuit.

---

**Grounding**

Risk of electrical shock! Always properly ground the pump. Conform to local electric codes.



Grounding

**Mise à la terre**

Veillez à ne pas faire fonctionner la pompe sans avoir au préalable prévu une mise à la terre. Celle-ci permettra d'éviter d'éventuelles décharges électriques. Vérifiez que le câble de mise à la terre est bien branché.

---

**Install a GFCI (earth leakage breaker)**

An electrical failure of the pump may adversely affect other devices on the same line. Purchase and install a GFCI (earth leakage breaker) separately.

Electrical  
shock**Détecteur de fuites à la terre**

Un problème électrique peut affecter défavorablement le dispositif. Achetez et installez un détecteur de fuites à la terre.

---

**Preventative maintenance**

Follow instructions in this manual for replacement of wear parts. Do not disassemble the pump beyond the extent of the instructions.



Requirement

**Remplacement des pièces usées**

Suivez les instructions de ce manuel pour remplacer les pièces usées. Ne démontez pas la pompe au-delà des instructions.

---

**Do not use a damaged pump**

Use of a damaged pump could lead to an electric shock or death.



Prohibited

**N'utilisez pas une pompe endommagée**

Utiliser une pompe endommagée peut provoquer une décharge électrique ou la mort.

---

## Disposal of a used pump

Dispose of any used or damaged pump in accordance with local rules and regulations. If necessary, consult a licensed industrial waste disposal company.



Requirement

## Elimination des pompes usées

Elle doit se faire en conformité avec les règles locales en vigueur (consultez une entreprise certifiée et spécialisée).

---

## Check pump head bolts

Liquid may leak if any of the pump head bolts become loose. Tighten the bolts evenly to the following torque in diagonal order before initial operation and at regular intervals.

### Tightening torque

EWN-B11/-B16/-B21/-C16/-C21	: 19 lb-in
EWN-B31/-C31/-C36	: 22.6 lb-in



Caution

## Serrez la tête de pompe

La pompe peut fuiter si les boulons sont desserrés. Resserrez les boulons diagonalement et uniformément avant la première utilisation. Resserrez les boulons régulièrement pour éviter toute fuite.

### Couple de serrage

EWN-B11/-B16/-B21/-C16/-C21	: 19 lb-in
EWN-B31/-C31/-C36	: 22.6 lb-in

---

## Solution compatibility

This pump has been evaluated for use with water only. The suitability of this pump for use with liquids other than water, such as acid and alkaline, is the responsibility of the user. For liquids other than water, select the best-suited liquid end material combination using a chemical compatibility chart.



Caution

## Compatibilité avec la solution

Cette pompe a été évaluée pour l'utilisation avec l'eau uniquement. L'aptitude de cette pompe à être utilisée avec d'autres produits, tels que les acides et les alcalins, est de la responsabilité de l'utilisateur. Pour des liquides autres que l'eau, choisissez le matériel le plus compatible selon la résistance chimique.

## Precautions for use

- Electrical work should be performed by a qualified electrician. Otherwise, personal injury or property damage could result.



Le raccordement électrique de la pompe doit être effectué par du personnel qualifié sinon, il pourrait y avoir un dommage corporel ou incorporel.

- Do not install the pump:
  - In a flammable atmosphere.
  - In a dusty/humid place.
  - In direct sunlight or wind & rain.
  - Where ambient temperature can exceed 0-40°C.

Protect the pump with a cover when installing it out of doors.

Ne pas installer la pompe dans les endroits suivants:

- Dans une atmosphère inflammable
- Dans une atmosphère poussiéreuse ou humide.
- Sous les rayonnements du soleil, dans le vent ou sous la pluie.
- La température ambiante doit être comprise entre 0 et 40°C.

Protégez la pompe par un capot si vous l'installez dehors.

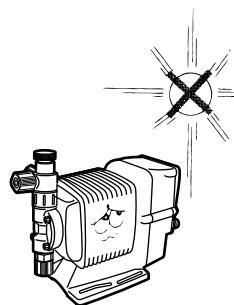

- Select a level location, free from vibration, that won't hold liquid. Anchor the pump with four M5 bolts so it doesn't vibrate. If the pump is not installed level, output may be affected.

Choisissez un endroit où il n'y a pas de vibrations et où le liquide peut s'évacuer. Fixez la pompe à l'aide de vis M5 de façon à ne pas avoir de vibrations. Si la pompe est inclinée, le débit peut être réduit.

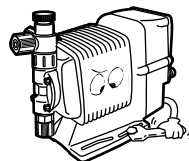

- When two or more pumps are installed together, vibration may be significant, resulting in poor performance or failure. Select a solid foundation (concrete) and fasten anchor bolts securely to prevent vibration during operation.



Si plusieurs pompes sont installées ensemble, elles interagissent et les vibrations peuvent devenir importantes, ce qui engendre des performances médiocres ou des ratures. Choisissez un endroit solide et fixez les boulons correctement pour éviter les vibrations pendant le fonctionnement.

- Allow sufficient space around the pump for easy access and maintenance.



Prévoyez de l'espace autour de la pompe pour faciliter l'accès et la maintenance.

- Install the pump as close to the supply tank as possible.



Installez la pompe le plus près possible du tank de produit.

- When handling liquids that generate gas bubbles (sodium hypochlorite or hydrazine solution), install the pump in a cool and dark place. Flooded suction installation is strongly recommended.



Installez la pompe dans une place froide à l'abri du soleil lorsqu'il s'agit du dosage de produits dégazant tels que l'hypochlorite de sodium ou l'hydrazine. Mettre la pompe en charge est vivement recommandé.

- Use care handling the pump. Do not drop. An impact may affect pump performance. Do not use a pump that has been damaged to avoid the risk of electrical damage or shock.

Veillez à ne pas laisser tomber la pompe sur le sol. Un impact important pourrait réduire les performances de la pompe. Ne pas utiliser une pompe endommagée sinon il pourrait y avoir un courant de fuite ou une décharge électrique.

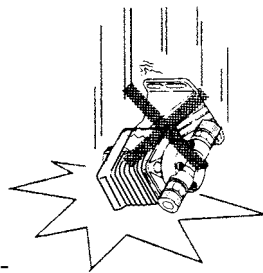

- The pump has a rating of IP65, but is not waterproof. Do not operate the pump while wet with solution or water. Failure or injury may result. Immediately dry off the pump if it gets wet.

Le pompe est IP65 mais n'est pas complètement étanche. Ne pas laisser la pompe couverte de liquide pompé ou sous la pluie. Il pourrait y avoir des ratés ou préjudices. Si la pompe a été mouillée, sechez-la directement.



Caution

- Do not close discharge line during operation. Solution may leak or piping may break. Install a relief valve to ensure safety and prevent damaged plumbing.

Ne fermez pas la ligne de refoulement lorsque la pompe est en fonctionnement sinon il pourrait y avoir des fuites de liquide ou la tuyauterie pourrait céder. Installez une soupape de sécurité pour des raisons de sécurité et pour éviter tout dommage de la tuyauterie.



Caution

- Do not remove the control unit. Note that an applicable control unit differs with each drive unit. Do not attach a control unit to a different drive unit. Otherwise, an electrical circuit or the drive unit may fail.

N'enlevez pas l'unité de contrôle. Chaque partie électromagnétique a son propre unité de contrôle. Ne mettez pas autre unité de contrôle au module de puissance sinon il pourrait y avoir un court circuit ou un dysfonctionnement de la partie électromagnétique.



Caution

- Solution in the discharge line may be under pressure. Release the pressure from the discharge line before disconnecting plumbing or disassembly of the pump to avoid solution spray.

Le liquide au refoulement peut être sous pression. Relâchez la pression du refoulement avant de démonter la pompe ou d'enlever le tubage pour éviter tout jet de liquide.



- Wear protective clothing when handling or working with pumps. Consult solution MSDS for appropriate precautions. Do not come into contact with residual solution.

Portez un équipement de sécurité lorsque vous manipulez la pompe. Consultez le MSDS pour utiliser les précautions appropriées. Évitez tout contact avec le liquide chimique.



- Do not clean the pump or nameplate with a solvent such as benzine or thinner. This may discolour the pump or erase printing. Use a dry or damp cloth or a neutral detergent.

Ne nettoyez pas la pompe ou la plaque signalétique à l'aide d'un solvant comme le benzène ou le white spirit. Cela pourrait décolorer la pompe ou effacer l'impression. Utilisez un tissu sec ou mouillé avec de l'eau ou un détergent neutre.



- This pump has been evaluated for use with water only. Cette pompe a été testée uniquement avec de l'eau.



# Overview

**Pump characteristics, features and part names are described in this section.**

## Introduction

### Pump structure & Operating principle

The EWN series is a diaphragm metering pump which consists of a pump head, drive unit and control unit. A diaphragm is directly driven by electromagnetic force.

#### Principle of operation

The electromagnetic force and spring force make reciprocating motion. The reciprocating motion is transferred to a diaphragm through a plunger and then volumetric change occurs in the pump head. This action transfers liquid along with pump head valve action.

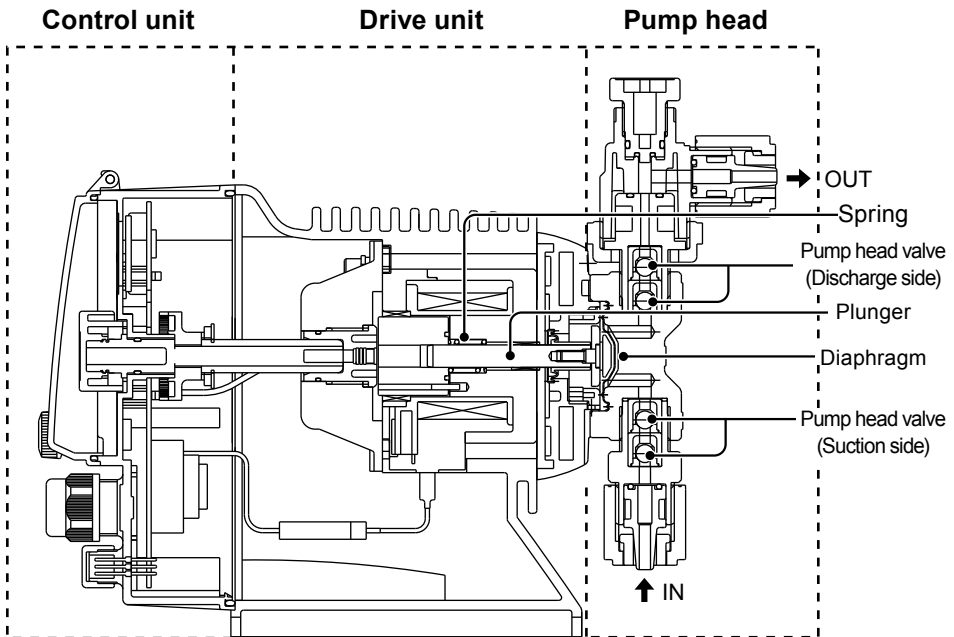



## • Auto degassing system

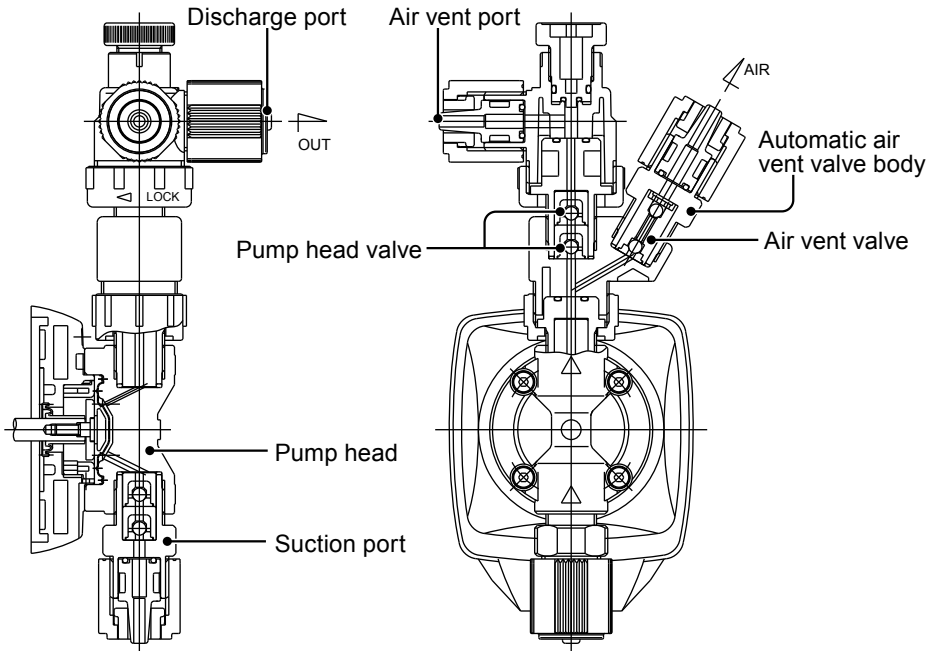

- Once air is entrained through the suction port, the working pressure difference between the pump head valve and the air vent valve separates entrained air from liquid.
- Entrained air is expelled to open air through the automatic air vent valve body.
- Only liquid is delivered to a discharge line through the discharge port. Note a small amount of liquid is expelled with entrained air.

## Features

- **Multivoltage operation**

The EWN-R series is a multivoltage type (100-240VAC) and can be selected without concern for local power voltage.

- **High turndown ratio**

Digitally-controlled stroke rate range is 0.1-100%. The stroke length shifts for a fine flow adjustment.

- **Waterproof and dustproof structure (IP65)**

With the aim of improving resistance to exposure to liquid, the control unit is installed on the back of the pump and the control panel is protected with a cover as standard equipment. A rubber gasket is provided between the pump head and the bracket to prevent water from entering from the periphery of the pump head.

\*This pump is not completely water resistant. Protect the pump with a cover when installing it out of doors.

## Operational functions

- **Manual operation (see page 54)**

The start/stop of the pump by key operation

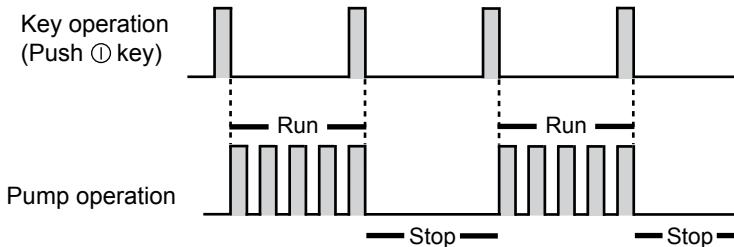

\*Manual operation can be done at any time during operation or stop.

- **EXT operation (see page 55)**

The pump operation by the external signal.

The external operation is available after multiplier or divisor programming.

**Multiplier programming (See page 57)**

1-9999 shots can be programmed to one pulse signal.

\*In the EXT operation, the pump runs at the manual operation stroke rate.

\*The pump makes one shot per pulse when the multiplier is programmed to 1.

Example) When the multiplier is programmed to 5, the pump makes five shots per signal.

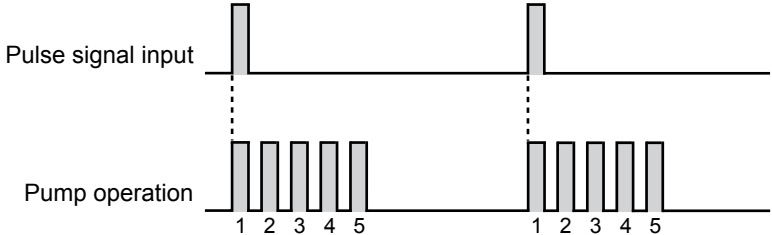

A buffer works when the pump receives an external signal before the programmed shots per signal is completed.

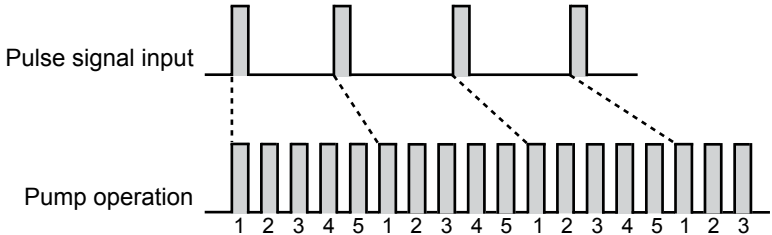

\*The buffer stores the external signals for up to 65535 shots.

**Divisor programming (See page 59)**

1-9999 pulse signals can be programmed to make one shot.

\*The pump can not run over a programmed stroke rate (max. 100%) even if a divisor is set to run the pump faster.

\*The pump makes one shot per pulse when a divisor is programmed to 1.

Example) When a divisor is programmed to 5, the pump makes one shot per 5-signal.

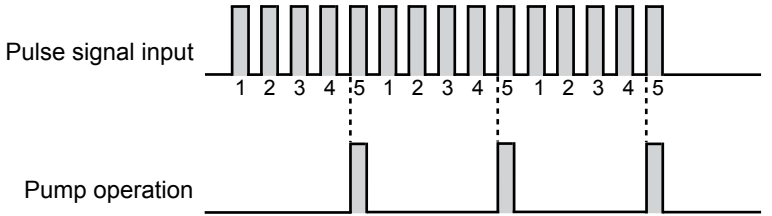

**ANA. R (analogue rigid) programming (See page 63)**

The pump increases/decreases a flow rate in proportion to 0-20mA. Four (4-20, 20-4, 0-20, 20-0) programs are provided.

In "4-20" or "20-4" program a disconnection sensor works to stop the pump as a current value falls below 4mA ("DISCN" blinks on the screen). Check wiring as necessary. Pushing the start/stop key, this state is released.

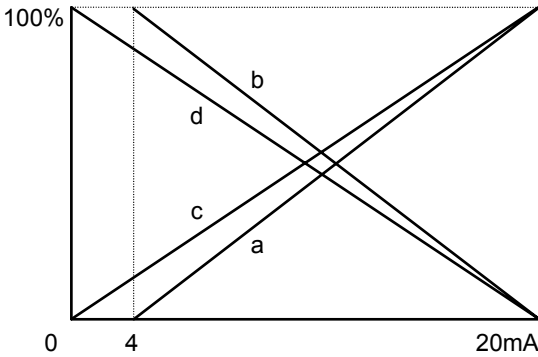

Condition  
 The left graph is in the following programs.  
 a. 4-20 (Default setting)  
 b. 20-4  
 c. 0-20  
 d. 20-0

**ANA. V (analogue variable) programming (See page 61)**

The pump increases/decreases a flow rate in proportion to 0-20mA. Setting two points can draw a straight line. Depending on the position of the two points, 0 % may not come at 0mA in some cases. When a stroke rate could become over 100% at some mA due to the setting, pump speed is limited to 100%.

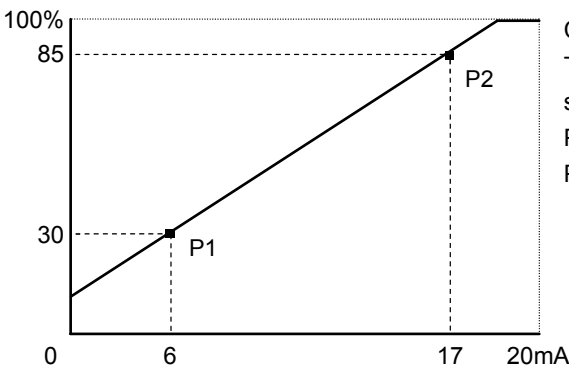

Condition  
 The left graph is in the following setting.  
 P1 = 6 mA, 30%  
 P2 = 17 mA, 85%

- **STOP function (See page 66)**

The start/stop of the pump can be controlled by the external signal.

**When "NOR. OP" is selected:**

The pump stops while receiving the external signal via the STOP terminal.

\*The pump resumes operation when the STOP signal is released.

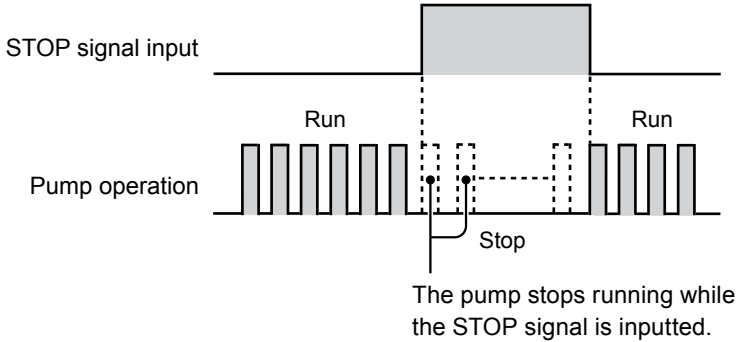

**When "NOR. CL" is selected:**

The pump runs while receiving the external signal via the STOP terminal.

\*The pump stops operation when the stop signal is released.

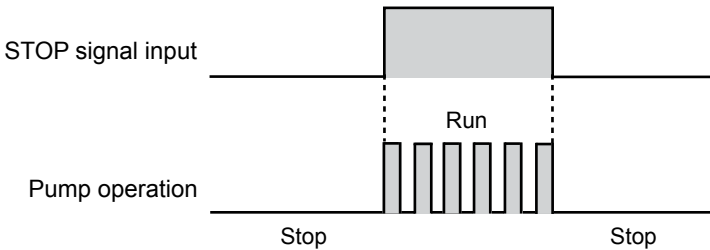

- **Pre-STOP function (See page 66)**

**When "NOR. OP" is selected:**

The STOP LED lights orange while the pump receiving the external signal via the Pre-STOP terminal (a contact is closed). Note the pump does not stop running.

**When "NOR. CL" is selected:**

The STOP LED stops lightening while the pump receiving the external signal via the Pre-STOP terminal (a contact is closed).

● **AUX function (See page 43)**

The pump runs at the maximum stroke rate while receiving the external signal via the AUX terminal. Use this function for degassing.

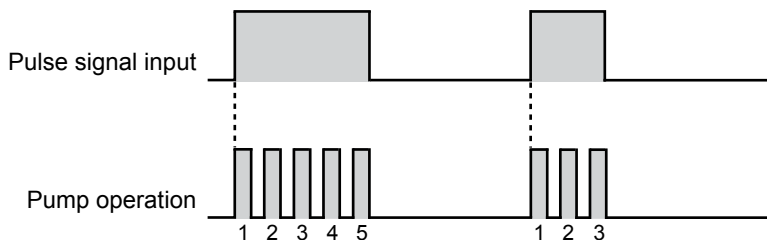

● **Priming function (See page 43)**

The pump runs at the maximum stroke rate while both the UP and DOWN keys are pressed. Use this function for degassing.

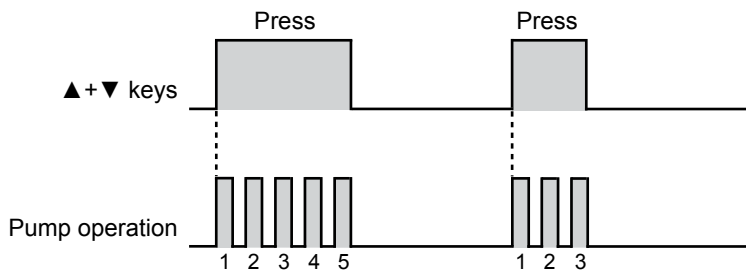

● **OUTPUT function (See page 70)**

Signals can be sent via the output terminal in sync with manual operation. The terminal can be set to on or off.

## Part names

### Pump

#### Adjusting screw

Used for opening the air vent port.

#### Air vent port

Always connect a tube.  
Be sure to return the tube end to a supply tank or a container.  
The air vent port can rotate 90 degrees.

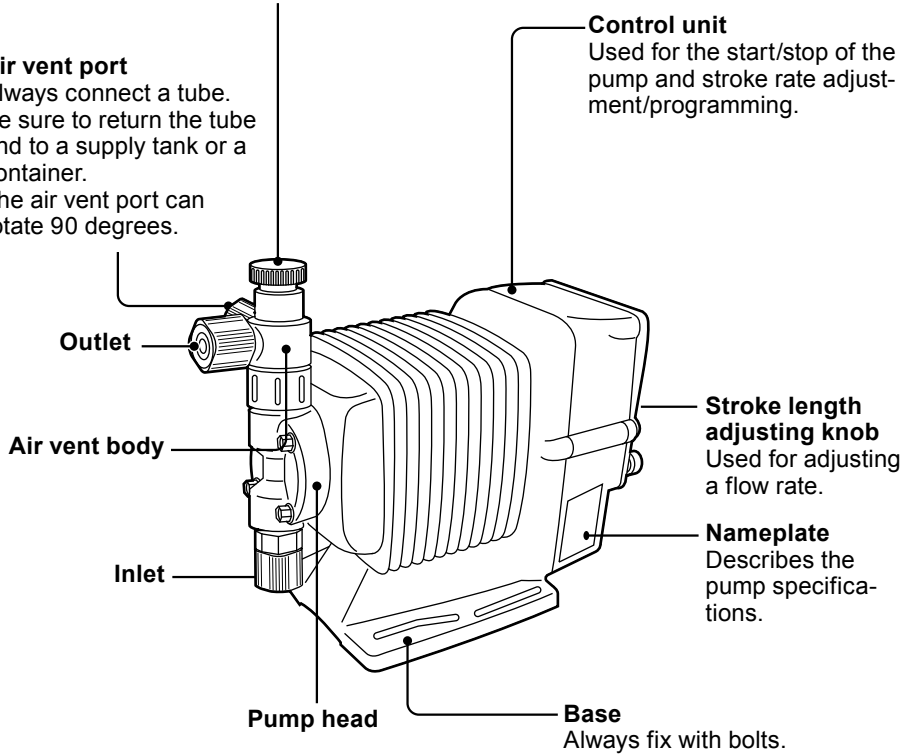

# Operational panel

## Display

An operational status, a selected mode and a programmed value are shown here.

## START/STOP key

Used for starting/stopping the pump operation.

## EXT key

Used for entering the EXT mode.

## UP key

Used for increasing numeric values or selecting a programming mode.

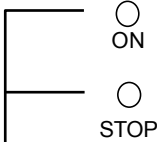
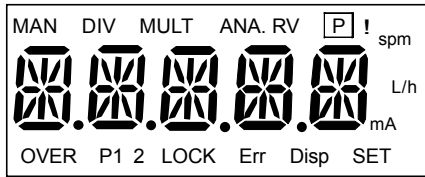

## LED

Lights as the pump is turned on and blinks at each shot.

## DOWN key

Used for decreasing numeric values or selecting a programming mode.







## DISP key

Used for checking flow information or changing units.

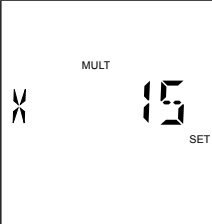
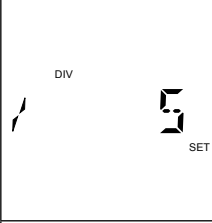

## ■ Basic displays & Pump states

	STOP LED lights red	ON LED lights orange	ON LED lights green	ON LED blinks green
MAN 100.0%	—	Manual wait state. Display shows stroke rate in %.	—	The pump is running in manual mode. Display shows stroke rate in %.
MULT 15	—	—	EXT(Multiply) mode. The pump is waiting for the external signal.	EXT(Multiply) mode. The pump is making the displayed # of shots per signal.
DIV 10.5%	—	—	EXT(Divide) mode. The pump is waiting for the external signal.	EXT(Divide) mode. The pump is running at the displayed stroke rate.
ANA. R 20.0%	—	—	EXT(ANA. R) mode. The pump is wait- ing.	EXT(ANA. R) mode. The pump is running at the displayed stroke rate.
ANA. V 100.0%	—	—	EXT(ANA. V) mode. The pump is wait- ing.	EXT(ANA. V) mode. The pump is running at the displayed stroke rate.
AUX	—	—	—	AUX mode. The pump is running at the maximum stroke rate.

	STOP LED lights red	ON LED lights orange	ON LED lights green	ON LED blinks green
	—	EXT(Multiply) programming mode. The pump is set to make the displayed # of shots per signal.	—	—
	—	EXT(Divide) programming mode. The pump is set to make one shot for the displayed # of signals.	—	—
	Operation stop by the STOP signal. ON LED lights green.	—	—	—
	STOP signal input in the manual wait state. ON LED lights orange.	—	—	—
	Keypads are locked. Keypad operation is ineffective in this state. Release keypad lock before operation.			
	—	—	—	PRIME mode. The pump is running at the maximum stroke rate.

## Identification codes

The model codes of the pump/drive units and the control unit represent the following information.

### Pump/Drive units

**EWN - B 11 VC**  **U R**  -   
**a b c d e f g h i**

#### a. Series name

EWN: Multivoltage electromagnetic metering pump

#### b. Drive unit (Average power consumption)

B: 20W

C: 24W

#### c. Diaphragm effective diameter

09: 8mm      11: 10mm      16: 15mm

21: 20mm      31: 30mm      36: 35mm

#### d. Wet end materials

Code	Pump head	Valve	O ring	Valve seat	Gasket	Diaphragm
VC	PVC	CE	FKM	FKM	PTFE	PTFE + EPDM
VH		HC276	EPDM	EPDM		
VE		CE	EPDM	EPDM		
PC	GFRPP	CE	FKM	FKM		
PH		HC276	EPDM	EPDM		
PE		CE	EPDM	EPDM		
FC	PVDF	CE	PCTFE	—		
TC			FKM	FKM		
SH	SUS316	HC276	SUS316	—		

#### Automatic air vent (Auto degassing type)

Code	Air vent valve guide A	Air vent valve guide B	Valve	Separate pin	Valve seat	O ring
VC	PVC	PVC	CE	Titanium	FKM	FKM
VH			HC276	HC276	EPDM	EPDM

#### Material code

PVC : Transparent polyvinyl chloride      GFRPP : Glassfiber-reinforced polypropylene  
 PVDF : Polyvinylidene difluoride      EPDM : Ethylene-propylene rubber  
 FKM : Fluorine-contained rubber      PTFE : Polytetrafluoroethylene  
 HC276 : HASTELLOY C276      SUS316 : Austenite stainless steel  
 CE : Alumina ceramics      PCTFE : Polymonochlorotrifluoroethylene

### e. Tube connection bore

No.	Hose size (ID×OD)	Wet end materials	Pump models
No code*	ø1/4"×ø3/8"	VC/VH/VE/PC/PH/PE/TC/VC/ VH/VE-C/VC-A/VH-A	EWN-09/-11/-16 & -21
	ø3/8"×ø1/2"	VC/VH/VE/PC/PH/PE/TC	EWN-31 & -36
	1/4-18NPT	FC/SH/SH-H/SH-H2	EWN-11/-16/-21/-31 & -36
	IN/AIR: 1/4"×ø3/8" OUT: 1/4-18NPT	PC/PE-H/PE-H2	EWN-11 & -16
	IN: ø15×ø22 OUT: ø3/8"×ø1/2"	P6-V	EWN-31
1	ø4×ø9	VC/VH/VE/PC/PH/PE/VC/ VH/VE-C/VC-A/VH-A	EWN-09/-11/-16 & -21
2	ø4×ø6	VC/VH/VE/PC/PH/PE/TC/VC/ VH/VE-C/VC-A/VH-A	EWN-09/-11/-16 & -21
3	ø6×ø8	VC/VH/VE/PC/PH/PE/TC/VC/ VH/VE-C/VC-A/VH-A	EWN-09/-11/-16 & -21
4	ø8×ø13	VC/VH/VE/PC/PH/PE	EWN-31 & -36
5	ø9×ø12	VC/VH/VE/PC/PH/PE	EWN-31 & -36
6	ø10×ø12	VC/VH/VE/PC/PH/PE	EWN-31 & -36
23	ø6×ø12	VC/VC-C	EWN-09/-11/-16 & -21
24	ø5×ø8	VC/TC/VC-C	EWN-09/-11/-16 & -21
1/10	IN: ø4×ø9 OUT: 1/4-18NPT	PC/PH/PE-H	EWN-11 & -16
2/10	IN: ø4×ø6 OUT: 1/4-18NPT	PC/PH/PE-H	EWN-11 & -16
3/10	IN: ø6×ø8 OUT: 1/4-18NPT	PC/PH/PE-H	EWN-11 & -16

\* ø4×ø6 and ø6×ø12 are equipped to the EWN-09/-11/-16/-21 (VC-C type).

### f. Power cable

U: American 115VAC type

U2: American 230 VAC type

### g. Control unit function

R: Standard

### h. Special version

C: High compression type

H: High pressure type

V: High viscosity type

A: Auto degassing type

### i. Special configuration

H2: High pressure type (2MPa)

# Installation

***This section describes the installation of the pump, tubing and wiring. Read through this section before work.***

**!** Observe the following points when installing the pump.

- Be sure to turn off power to stop the pump and related devices before work.
- Upon sensing abnormality or danger, stop work immediately. Remove problems before resuming work.
- Do not place dangerous or flammable goods near the pump for your safety.
- Risk of an electrical leak or shock. Do not use a damaged pump.

## Pump mounting

*Select an installation location and mount the pump.*

### Necessary tools

- Four M5 bolts (pump mounting)
- Adjustable wrench or spanner

### 1 Select a suitable place.

Always select a flat floor free of vibration. See the "Precautions for use" section for detail.

Flooded suction is recommended when handling a gaseous liquid such as sodium hypochlorite.

### 2 Anchor the pump by the M5 bolts.

Be sure to fix the pump at four points.

#### NOTE

Install the pump horizontally. If the pump is installed at a tilt, a flow may reduce.

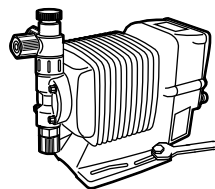

# Pipework

Connect tubes to the pump and install a check valve.

## Before operation

- Cut the tube ends flat.

Tube end (Side view)

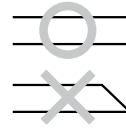

## Necessary tools

- Adjustable wrench or spanner

## Tube connection

- Pass a tube into the fitting nut and hose stopper and then slide it down to the hose adapter as far as it will go.
- Fit the tube end (hose adapter) to the fitting. Then hand tighten the fitting nut.
- Retighten the fitting nut by turning it 180 degrees with an adjustable wrench or spanner.

\*The plastic fitting nut may be broken if it is tightened too much.

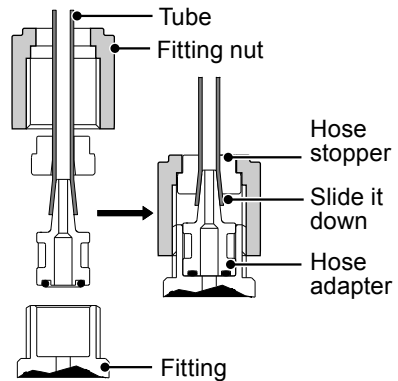

- 1** Connect tubes into the inlet and outlet.

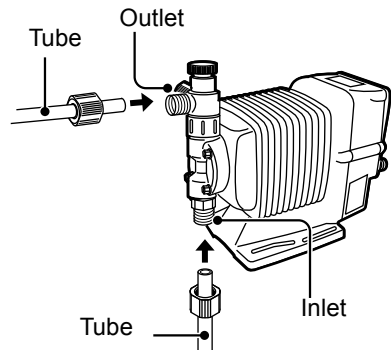

## 2 Connect an air bleed tube into the air vent port.

Route back the other tube end to a supply tank or a container.

For the auto degassing type, connect another air bleed tube into the automatic air vent valve body as well.

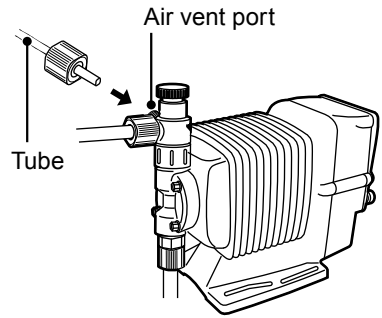

## 3 Decide an air vent port direction.

The air vent port can rotate 90 degrees.

- Turn the lock nut anticlockwise.
- Adjust the direction of the air vent port.
- Hand-tighten the lock nut, holding the air vent body A.
- Turn the lock nut 90 degrees clockwise further with an adjustable wrench or spanner.

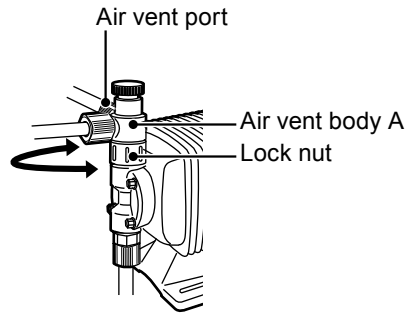

### NOTE

The air vent port is not provided to the EWN-FC type. Purchase and install an air vent valve.

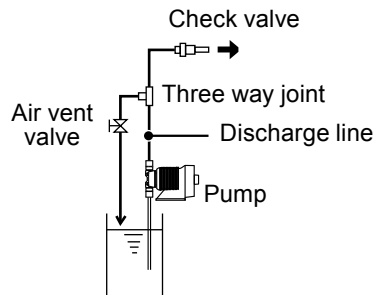

## Check valve mounting

Install an optional check valve to the EWN (or a back pressure valve to the FC type) for the prevention of a back flow, siphon and overfeeding.

In the following cases be sure to install the check valve.

- A suction side liquid level is higher than a discharge side or an injection point at atmospheric pressure.

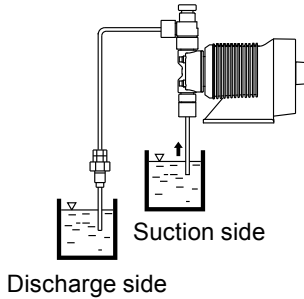

- A discharge side liquid level is higher than a suction side but the distance is 5m or below.

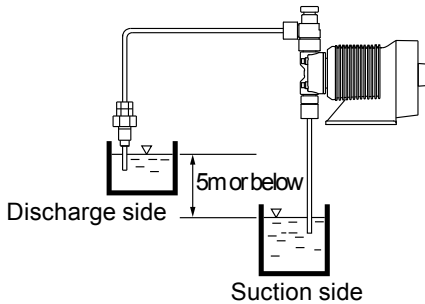

- A suction line pressure is higher than a discharge line pressure.

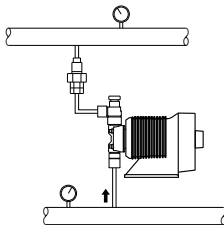

- A discharge pressure (including pipe resistance and discharge head) is below 0.13MPa. (0.049MPa for B31 and C36).



# 1

## Mount a check valve at the discharge tube end.

\*The CAN/CBN check valve and the BVC back pressure valve have R1/2 and R3/8 thread connections as well as a tube connection. Cut off unnecessary sections before use.

### CAN check valve

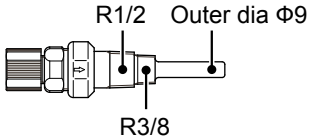

### BVC back pressure valve

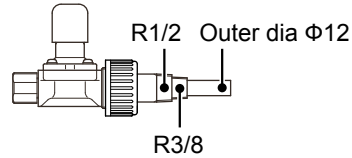

\*The CBN check valve of which the both ends are tube connections is also available. Contact us or your nearest distributor.

### CBN check valve

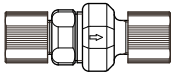

## NOTE

Periodically clean or replace a check valve with new one for the prevention of crystal clogging.

## Tubing layout

### Flooded suction application

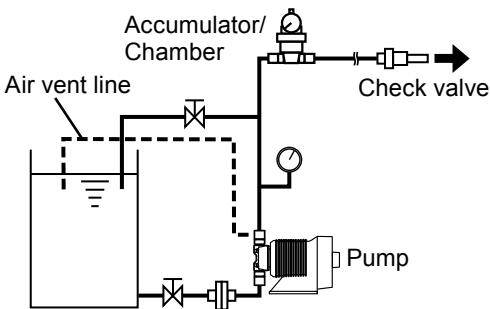

### Suction lift application

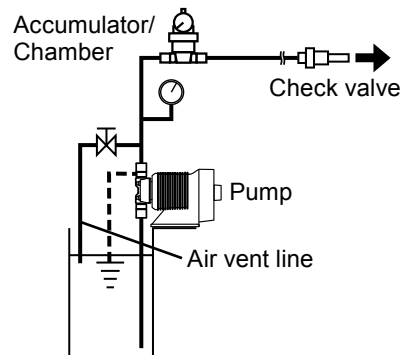

\*Flooded suction is recommended when handling a gaseous liquid such as sodium hypochlorite. For the auto degassing type, keep a suction lift at 1m or below. Otherwise, the air vent valve may not function. Before resuming operation, always perform degassing by using the adjusting screw.

\*Do not lay the air vent line upwards, or the line may be blocked by liquid.

### *Wiring for a power voltage and an external signal.*

#### **!** Observe the following points during wiring work.

- Electrical work should be performed by a qualified operator. Always observe applicable codes or regulations.
- Observe the rated voltage range, or the electrical circuit in the control unit may fail.
- Do not perform wiring work while electric power is on. Otherwise, an electrical shock or a short circuit may result. Be sure to turn off the power before wiring work.
- Be careful for electric power not to be turned on during work.
- Replacement of a power cable should be conducted by a manufacturer, his agency or a skilled person. Otherwise, an accident may result.
- This pump is supplied with a grounding conductor and ground-type attachment plug. To reduce the risk of electric shock, be certain that it is connected only to a properly grounded, grounding type receptacle.

#### **Necessary tools**

- Adjustable wrench or spanner
- Phillips screw driver
- Precision screw driver

### **Power voltage/Earthing**

Check that the main power is turned off.

#### **1** Insert the plug all the way seated in a jack.

This product have two power wires and one earth wire, and is classified as class I.

\*Make sure the earth plug is seated in securely as well.

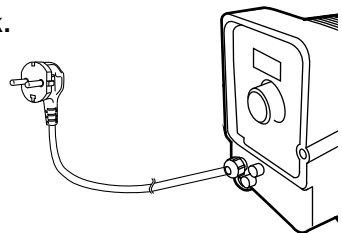

## NOTE

- Do not share a power source with a high power device which may generate surge voltage. Otherwise an electronic circuit may fail. The noise caused by an inverter also affects the circuit.
- Energize the pump with a power voltage via a mechanical relay or switch. Do not fluctuate the voltage, or CPU may malfunction. See page 37 for the precautions for ON-OFF control by a mechanical relay.

### Apply power at a sitting

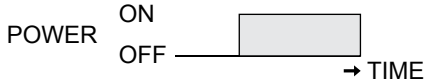

### Do not apply gradually

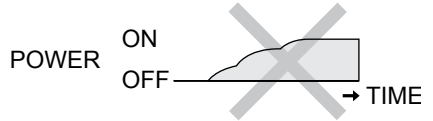

## Surge voltage

The electronic circuit in the control unit may fail due to surge voltage. Do not place the pump close to a high power device of 200V or more which may generate large surge voltage. Otherwise, take any of the following measures.

- Install a surge absorption element (ex. a varistor with capacity of 2000A or more) via power cable.

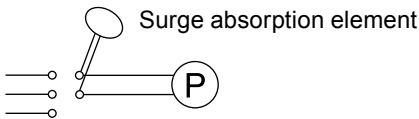

### Recommended varistors

Panasonic ERZV14D431

KOA NVD14UCD430

See manufacturer's catalogues for detail.

- Install a noise cut transformer via power cable.

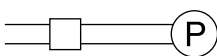

Noise cut transformer

### Precautions for ON-OFF control by a mechanical relay

The control unit is equipped with CPU. Always start/stop the pump by the STOP signal for ON-OFF control. Try not to turn on and off the main power. Otherwise, observe the following points.

- Do not turn ON/OFF power voltage more than six times per hour.
- When using a mechanical relay for ON-OFF operation, its contact capacity should be 5A or more. Contact point may fail if it is less than 5A.
- If a mechanical relay with the contact capacity of 5A is used, the maximum allowable ON/OFF operation is about 150,000 times. The contact capacity should be 10A or more when making ON-OFF operation over 150,000 times or sharing a power source with a large capacity equipment. Otherwise a contact point may fail by surge voltage.
- Use a solid state relay (SSR) as necessary (such as the OMRON G3F). See manufacturer's catalogues for detail.

### Signal wire connection

Use DIN 4- or 5-pin female connector cables. We recommend the use of Binder connector cables (German manufacturer). Contact us for detail.

#### *Binder connector cables*

5-pin : 713 series 99-0436-10-05    *Input signals*

4-pin : 715 series 99-0430-15-04    *Level sensor signal*

Connect these cables according to the following procedures. See manufacturer's instructions when using other connectors than Binder.

### Points to be checked

- Check that the main power is turned off.  
The pump is still charged right after turning off power. Wait for one minute before wiring.

## NOTE

- Do not lay on these signal cables in parallel with a power cable or combine them in a concentric cable (ex. 5 wires cable). Otherwise noise is generated through the cables due to induction effect and it results in malfunction or failure.
- The following products are the recommended SSRs (Solid State Relays) for signal input. Any other SSRs may cause malfunction. See manufacturer's information for details on these SSRs.
  - OMRON G3FD-102S or G3FD-102SN
  - OMRON G3TA-IDZR02S or G3TA-IDZR02SM
- When using a mechanical relay for signal input, its minimum application load should be 5mA or below.

\*Use either a no-voltage contact or an open collector for the Input and Level sensor signals.

\*Set pulse duration in 10-100ms (100Hz or below).

### 1 Take apart the DIN connector as necessary to pass a cable through it.

A cable diameter should be  $\varnothing 4 - \varnothing 6$ . Otherwise, the DIN connector can not seal the cable.

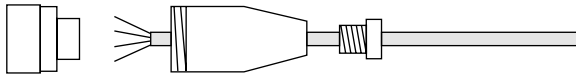

### 2 Strip the wire ends to connect and secure them to each position.

A cross sectional area of a wire should be  $0.75\text{mm}^2$  or below.

### 3 Assemble the DIN connector.

Pull the cable lightly so as to check it is secured enough. If it is loose, the connector can not seal the cable.

■ **Connections**

• **Level sensor**

The EWN have two stage level sensor, the Pre-STOP and STOP alarms. Connect the pre-alarm signal to the Pre-STOP and the alarm signal to the STOP. The pre-alarm functions just to notify a low liquid level by flashing the LED orange while the pump is running. Use the STOP and COM2 when just one signal is used.

• *When using an open collector:*

Pay attention to polarity. Pre-STOP and STOP are plus(+), and COM2 is minus(-).

(Maximum 2.3mA at 12V)

• *When using a contact:*

The contact should be designed for an electronic circuit. The minimum application load should be 1mA or less.

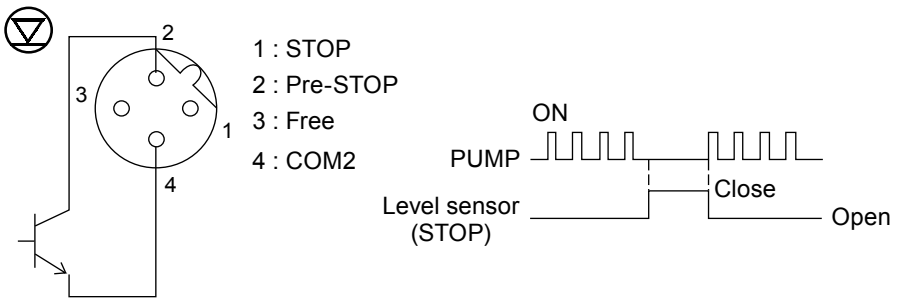

• **Stop function**

The pump stops running as receiving the external signal. Use the STOP and COM2.

NOTE

Frequent ON-OFF operation should be controlled via the Stop function. Otherwise, the number of ON-OFF times (turning on/off power) should be restricted to six times per hour.

### • Pulse signal

In the EXT (MULT or DIV) mode, the pump runs along with a multiplier or a divisor as receiving the pulse signal.

#### • When using an open collector:

Pay attention to polarity. Pulse is plus(+), and COM1 is minus(-).  
(Maximum 2.3mA at 12V)

#### • When using a contact:

The contact should be designed for an electronic circuit. The minimum application load should be 1mA or less.

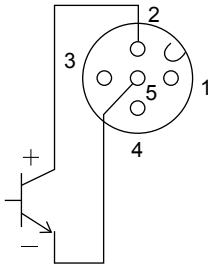

- 1 : Free
- 2 : Pulse
- 3 : Free
- 4 : Free
- 5 : COM1

### • Analogue signal

In the EXT (ANA.R or ANA.V) mode, the pump runs in a proportional control as receiving the analogue signal.

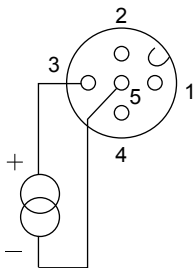

- 1 : Free
- 2 : Free
- 3 : ANA
- 4 : Free
- 5 : COM1

**• OUTPUT signal**

The pump sends out the OUTPUT signal along with injections or the STOP signal along with the external STOP signal input via a Photo MOS relay.

\*The maximum applied voltage is 24VAC/DC.

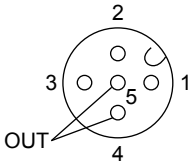

- 1 : Free
- 2 : Free
- 3 : Free
- 4 : OUT
- 5 : COM

**• AUX signal**

The pump runs at the max stroke rate as receiving the AUX signal.

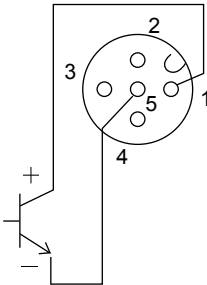

- 1 : AUX
- 2 : Free
- 3 : Free
- 4 : Free
- 5 : COM1



# Operation

***This section describes pump operation and programming.  
Run the pump after pipework and wiring are completed.***

## Before operation

Check a flow rate, tubing and wiring. And then perform degassing and flow rate adjustment before starting operation.

### ***Points to be checked***

*Before operation, check if:*

- Liquid level in a supply tank is enough.
- Tubing is securely connected and is free from leakage and clogging.
- Discharge/suction valves are opened.
- A power voltage is in the allowable range.
- Electrical wiring is correct and is free from the risk of short circuit and electrical leakage.

### ***Retightening of pump head fixing bolts***

#### **Important**

The pump head fixing bolts may loosen when plastic parts creep due to temperature change in storage or in transit, and this can lead to leakage. Be sure to retighten the bolts evenly to the specified tightening torque below in diagonal order before starting operation.

#### **Tightening torque**

Model code	Torque	Bolts
EWN-B09•11•16•21	19 lb-in	M4 Hex. socket head bolt
EWN-B31	22.6 lb-in	M4 Hex. socket head bolt
EWN-C16•21	19 lb-in	M4 Hex. socket head bolt
EWN-C31	22.6 lb-in	M4 Hex. socket head bolt
EWN-C36	22.6 lb-in	M5 Hex. socket head bolt

\*Tighten fixing bolts once every three months.

## ■ Use of hexagon wrench instead of a torque wrench

Fasten the fixing bolts as tight as can be by the hand with the straight long part of a hexagon wrench (a) and further turn the bolts clockwise 90 degrees with the short part (b).

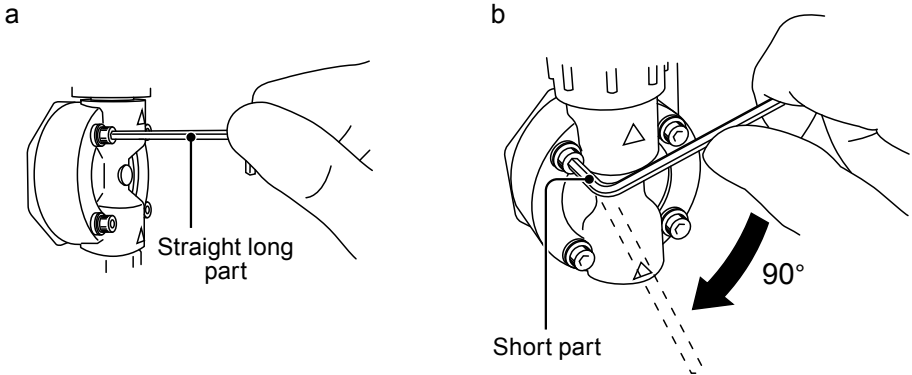

## ***Degassing***

*The gas needs to be expelled from the pump and tubing by degassing. Normal performance can not be obtained with gas in the pump. Conduct degassing in the following cases.*

- When the pump starts to run for the first time
- When a flow rate is too low
- After liquid is replaced in a supply tank
- After a long period of stoppage
- After maintenance and inspection

### NOTE

- Both gas and chemical come out together through an air bleed tube. Place the end of the tube in a supply tank or a container.
- Some chemicals may cause skin trouble or damage component parts. When your hand or component parts get wet with chemical liquid, wipe off immediately.
- For the auto degassing type, this process is not necessary as long as the air vent valve works effectively. But if air lock prevents this function, follow this process to expel gas.

### Points to be checked

- An air bleed tube is connected to the air vent port.
- For the auto degassing type, another air bleed tube is connected to the automatic air vent body.

Air bleed tube

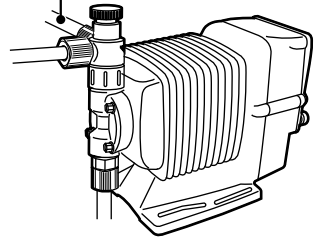

## 1 Turn on power.

The ON LED lights and a display related to the current mode appears on the screen.

\*The pump waits in the manual mode when the power is turned ON with a default setting or calls up the last selected mode with other settings.

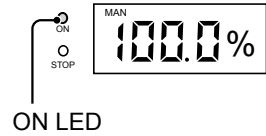

## 2 Rotate the adjusting screw two revolutions anticlockwise to open the air vent port.

\*Do not rotate it three revolutions. Otherwise, the adjusting screw may come off with solution spray.

Adjusting screw

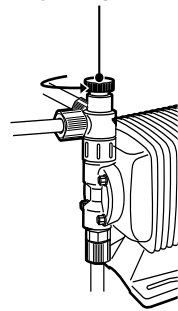

### 3 Run the pump at the maximum stroke rate.

Select a convenient way from the following.

- Set a stroke rate to 100% and run the pump manually.

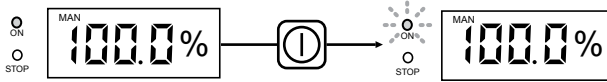

- Enter the external signal via the AUX terminals.

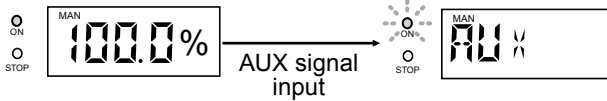

- Press and hold both the UP and DOWN keys.

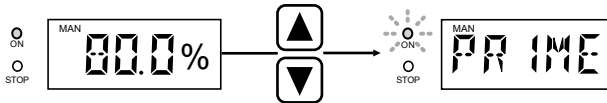

### 4 Keep the pump running for more than ten minutes for degassing.

### 5 Stop the pump by:

- pushing the start/stop key once or
- stopping the AUX signal or
- releasing the UP and DOWN keys

### 6 Rotate the adjusting screw clockwise to close the air vent port.

### 7 Check liquid is discharged.

\*Degassing is required again if the pump does not discharge liquid.

### 8 Check connections for leakage.

Degassing has now been completed.

\*The air vent port is not provided to the FC type. Install an air vent valve on a discharge line for degassing. See page 32 for detail. Also, the FC type has the threaded outlet & inlet, so that a tube can not be fit directory. Use general joints for tubing.

## ***Flow rate adjustment***

---

*A flow rate can be adjusted by adjusting a stroke rate and stroke length.*

The stroke rate is indicated in %. 100% stroke rate means the maximum flow rate. Stroke rate adjustment is a main way to adjust a flow rate.

Stroke length is the moving distance of the plunger.

A flow rate per shot can be controlled by changing stroke length. The widest moving distance is defined as 100% stroke length.

First adjust a flow rate by stroke rate adjustment. Use stroke length adjustment for the range where stroke rate adjustment can not reach.

Determine a suitable stroke rate and a stroke length, taking account of operating conditions and liquid characteristics.

The following procedure is recommended.

---

**1** **Change a stroke rate with stroke length 100% to adjust a flow rate.**

See "Stroke rate adjustment" on page 47 and "Stroke length adjustment" on page 49 for detail.

---

**2** **Measure a flow rate.**

---

**3** **If a flow rate is lower than a specified level, increase a stroke rate and measure the flow again.**

---

**4** **Change a stroke length for fine adjustment.**

---

**5** **Measure the flow again to see the specified level is obtained.**

---

# Flow rate, stroke rate and stroke length

## B type

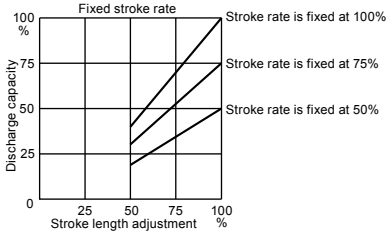

## C type

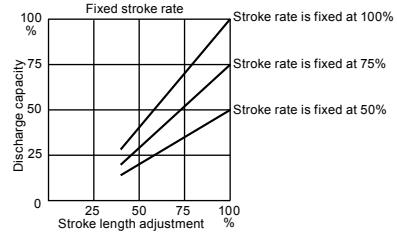

## Precautions of flow rate adjustment

- **When back pressure is high**

Set stroke length to 100% and adjust a flow by changing a stroke rate.

- **When a flow rate per shot greatly influences the reaction in neutralization or titration application**

Shorten a stroke length to reduce a flow rate per shot. And then adjust a flow by changing a stroke rate.

- **When pumping gaseous liquid such as sodium hypochlorite (NaClO) and hydrazine solution (N<sub>2</sub>H<sub>2</sub>O<sub>2</sub>)**

Set a stroke length to 100% and adjust a flow by changing stroke rate.

Note air lock may occur when a stroke length is set too short.

## ■ Stroke rate adjustment

A stroke rate can be set by keypad operation from 0.1 to 100%. The relation between a flow rate\* and a stroke rate is shown as below.

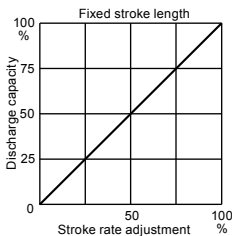

\*The flow rate described on the nameplate is at 100%.

## 1 Turn on power and call up manual mode.

Enter manual mode to indicate stroke rate on the screen.

- Push the start/stop key when "MULT", "DIV", "ANA.R" or "ANA.V" is on the screen.
- When "STOP" or "-STOP" appears on the screen, see "STOP function cancellation" on 68 page and release the STOP function.



## 2 Use the UP or DOWN key to adjust stroke rate.

- The stroke rate increases/decreases as pushing the UP/DOWN keys.
- Press and hold either key for three seconds for quick change. Quick change stops at 0.1% or 100%. 0.1% or 100% skips to 100% or 0.1% when the key is released and pushed once.

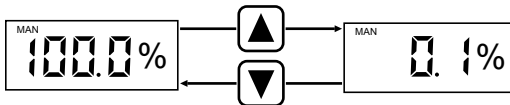

## 3 Push the start/stop key.

The ON LED blinks at each shot during operation.

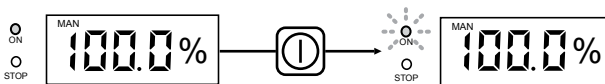

## ■ Stroke length adjustment

A stroke length can be adjusted when the moving distance of the plunger is changed by the stroke length adjusting knob.

The stroke length adjustment range is 50-100% for the B type, 40-100% for C type. The relation between a flow rate\* and a stroke length is shown as below.

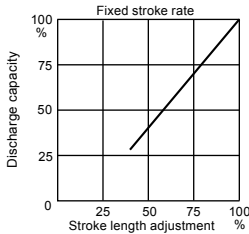

\*The flow rate described on the nameplate is at 100%.

### NOTE

Do not rotate the stroke length adjusting knob when the pump is not running.

## 1 Turn on power and push the start/stop key to run the pump.

The ON LED blinks during operation.

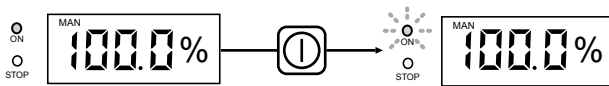

## 2 Rotate the stroke length adjusting knob and adjust a flow rate while the pump is running.

Stroke length adjusting knob

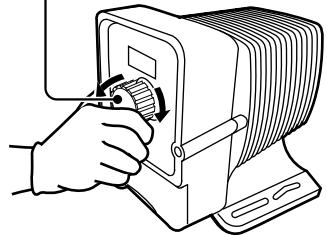



## ***Before a long period of stoppage (One month or more)***

---

### **Clean wet ends and the inside of tubing.**

- Run the pump with clean water for about 30 minutes to rinse chemicals off.

### **Before unplugging the pump**

- Always stop the pump by key operation and wait for three seconds before unplugging the pump. Otherwise, the last key operation may not be put in memory. In this case the pump unintentionally starts to run as powered on, discharging liquid.

### **When the pump does not transfer liquid at resuming operation.**

- Clean the valve sets and remove foreign matters.
- If gas is in the pump head, expel gas and readjust a flow rate. See "Degassing" on page 43 and "Flow rate adjustment" on page 46 for detail.

## Operation programming

Operation at each mode is individually set and controlled by keypad operation.  
Select a proper mode to make optimal operation.

### Default setting and setting range

Parameters	Default setting	Setting range	Step
Stroke rate* <sup>1</sup>	100.0%	0.1-100.0%	0.1* <sup>2</sup>
Multiply/Divide/Analogue selection	DIV	ANA-V, ANA-R, /N/NNN, XNNNN	-
Divisor	1	1-9999	1* <sup>3</sup>
Multiplier	1	1-9999	1* <sup>3</sup>
Analogue variable	-	0-20mA, 0-100%	0.1* <sup>2</sup>
Analogue rigid	4-20	4-20, 20-4, 0-20, 20-0	-
STOP function* <sup>4</sup>	NOR.OP	NOR.OP, NOR.CL	-
Pre-STOP function	NOR.OP	NOR.OP, NOR.CL	-
Analogue mode selection	ANA-R	ANA-R, ANA-V	-
Output function	STOP	STOP, SPM	-
CODE programming	00000	00000-99999	1
Unit selection	%	%, GPH, L/h, ml/min	-

\*1 The upper limit stroke rate in EXT mode

\*2 The flow rate increases/decreases as pushing the UP/DOWN keys. Press and hold either key for quick change.

\*3 A figure increases/decreases as pushing the UP/DOWN keys. Press and hold either key for quick change.

\*4 Note that the pump starts to run as returning to the wait state in the manual mode as long as the pump is receiving the STOP signal with "NOR.CL".

# Programming flow

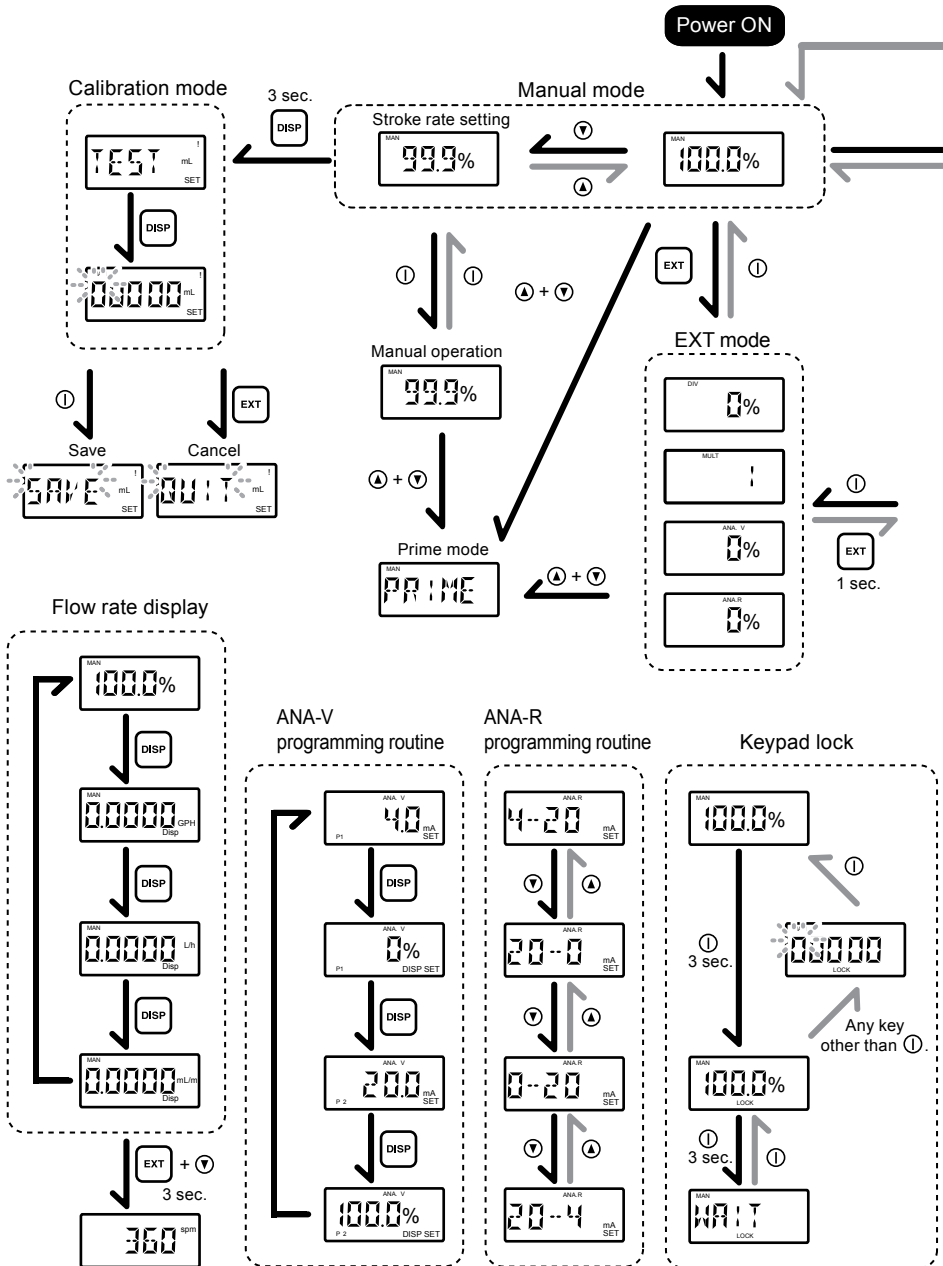

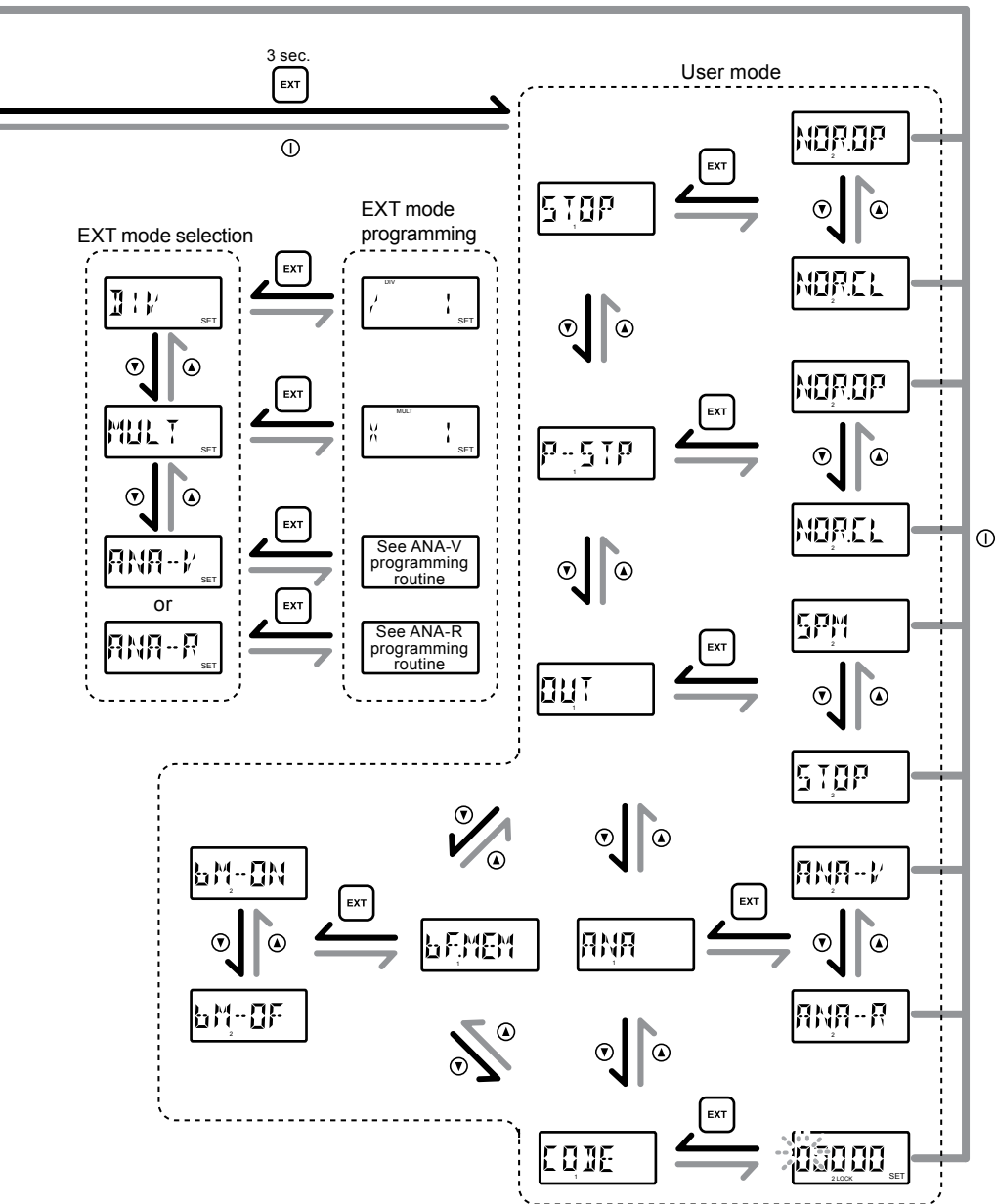

Operation

## 1 Turn on power.

The LED lights and a display related to the current mode appears on the screen.

\*The pump waits in the manual mode when turning on power with a default setting or calls up a previous mode at the last shutoff.



## 2 Enter manual mode.

Move to the next step when a stroke rate (0.1-100%) is shown on the screen.

**When "MULT", "DIV", "ANA-R" or "ANA-V" is on the screen:**

Push the start/stop key once to enter the wait state in the manual mode.

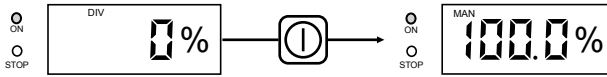

**When "STOP" or "-STOP" is on the screen:**

See "STOP function cancellation" on page 68 and release the function.

## 3 Use the UP or DOWN key to adjust stroke rate.

- A stroke rate increases/decreases as pushing the UP/DOWN keys.
- Press and hold either key for three seconds for quick change. Quick change stops at 0.1 or 100%. 0.1 or 100% skips to 100 or 0.1% when the key is released and pushed once.

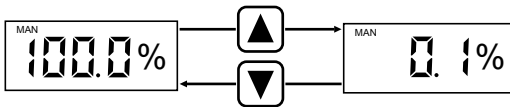

## 4 Push the start/stop key.

The pump starts to run.

- The LED blinks at each shot.

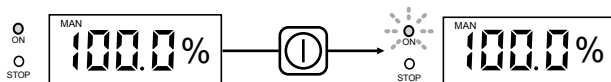

## EXT operation

The pump operation is controlled by the external (pulse) signal.

### ■ EXT mode

Set the upper limit spm and enter EXT mode. Note that the pump starts to run in sync with the external signal as entering EXT mode.

### NOTE

- Manual operation stroke rate is applied as the EXT upper limit spm. For example, even if a multiplier or a divisor is set to run the pump at 100% (360spm), the pump does not run over 50% (180spm) as long as manual stroke rate is 50%.
- A stroke rate skips from 100 to 0.1% by pushing the UP key once. Pay attention to this point when programming a stroke rate for the prevention of erroneous programming.

## 1 Enter manual mode.

Enter the manual mode to indicate a stroke rate on the screen.

- Push the start/stop key when "MULT", "DIV", "ANA-R" or "ANA-V" is on the screen.
- When "STOP" or "-STOP" appears on the screen, see "STOP function cancellation" on 68 page and release the STOP function.



## 2 Use the UP or DOWN key to program the upper limit.

Push the start/stop key and stop the pump when it is running. Then program stroke rate.

- A stroke rate increases/decreases as pushing the UP/DOWN keys.
- Press and hold either key for three seconds for quick change. Quick change stops at 0.1 or 100%. 0.1 or 100% skips to 100 or 0.1% when the key is released and pushed once.

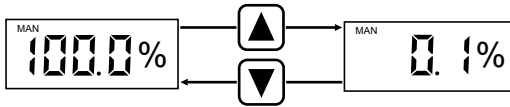

## 3 Push the EXT key to enter EXT mode.

Note that the pump starts to run in sync with the external signal as entering EXT mode.

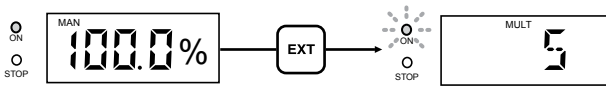

### ■ EXT mode programming

The following features can be programmed for the EXT operation.

#### • Multiplier programming

The number of shots per signal is programmed. A default setting is one shot per signal.

#### • Divisor programming

The number of signals per shot is programmed. A default setting is one shot per signal.

#### • Analogue programming

Current values are programmed for a proportional control.

### NOTE

Pushing the start/stop key, a program is entered. Do not forget to enter your programming. Note if the pump is unplugged before pushing the start/stop key, your programming is not stored.

## Multiplier programming

Program the number of shots per signal to control the pump. The number of shots can be programmed from 1 to 9999.

### NOTE

Do not enter the external signal during programming.

### 1 Enter EXT mode.

Push the EXT key to move from manual mode to EXT mode.

\*Push the start/stop key and stop the pump when it is running. Then call up EXT mode.

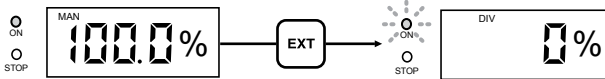

### 2 Press and hold the EXT key for one second and enter the EXT mode selection.

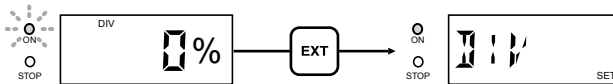

### 3 Select "MULT" (Multiply).

Scroll through the EXT mode selection by the UP and DOWN keys.

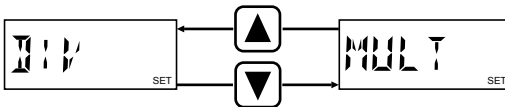



#### 4 Push the EXT key and call up the multiplier programming screen.

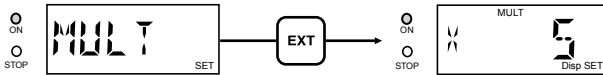

#### 5 Use the UP or DOWN key to program a multiplier.

- A multiplier increases/decreases as pushing the UP/DOWN keys.
- Press and hold either key for three seconds for quick change. Quick change stops at 1 or 9999. 1 or 9999 skips to 9999 or 1 when the key is released and pushed once.

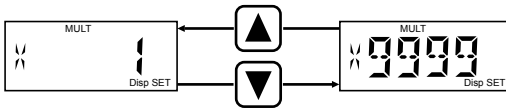

#### 6 Push the EXT key to return to the EXT mode selection.

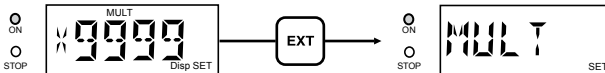

#### 7 Push the start/stop key to return to EXT mode.

The pump starts to run according to the multiplier programming.

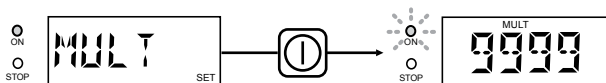

## Divisor programming

Program the number of signals per shot to control the pump. The number of signals can be programmed from 1 to 9999.

### NOTE

- If a divisor is programmed to 1 so as to make one shot per pulse and the input interval of the external signal is close to a manual operation stroke rate (but not exactly in synchronization), irregular operation may occur. This irregular operation occurs as the external signal is cancelled. Note that this is not malfunction. In order to avoid this phenomenon, perform 1:1 operation by programming a multiplier to 1.
- Do not enter the external signal during the programming.

### 1 Enter EXT mode.

Push the EXT key to move from manual mode to EXT mode.

\*Push the start/stop key and stop the pump when it is running. Then call up EXT mode.

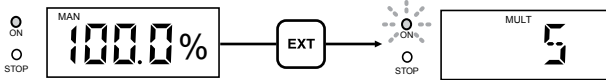

### 2 Press and hold the EXT key for one second and enter the EXT mode selection.

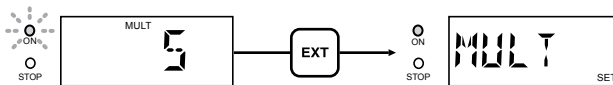

### 3 Select "DIV" (Divide).

Scroll through the EXT mode selection by the UP and DOWN keys.

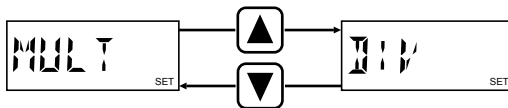

#### 4 Push the EXT key and call up the multiplier programming screen.

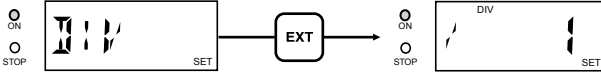

#### 5 Use the UP or DOWN key to program a divisor.

- A divisor increases/decreases as pushing the UP/DOWN keys.
- Press and hold either key for more than three seconds for quick change. Quick change stops at 1 or 9999. 1 or 9999 skips to 9999 or 1 when the key is released and pushed once.

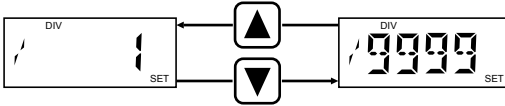

#### 6 Push the EXT key to return to the EXT mode selection.

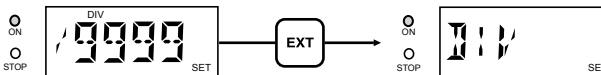

#### 7 Push the start/stop key to return to EXT mode.

The pump starts to run according to the multiplier programming.

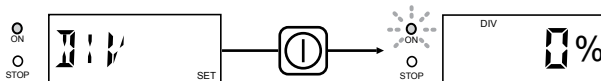

Flow rate display changes every time the DISP key is pressed.

# ANA-V programming

Select "ANA-V" or "ANA-R" in USER mode. See page 72.

## 1 Enter EXT mode.

Push the EXT key to move from manual mode to EXT mode.

\*Push the start/stop key and stop the pump when it is running. Then call up EXT mode.

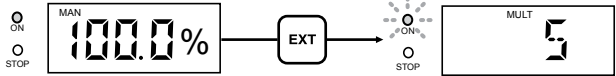

## 2 Press and hold the EXT key for one second and enter the EXT mode selection.

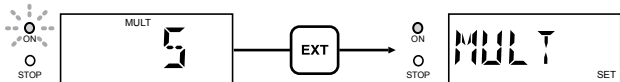

## 3 Select "ANA-V" (Analyse variable).

Scroll through the EXT mode selection by the UP and DOWN keys.

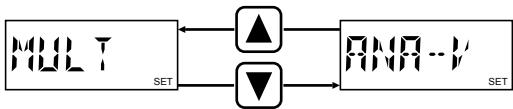

## 4 Push the EXT key and enter a current value at P1.

- A current value increases/decreases as pushing the UP/DOWN keys.
- Press and hold either key for three seconds for quick change. Quick change stops at 0.0 or 20.0mA. 0.0 or 20.0mA skips to 20.0 or 0.0mA when the key is released and pushed once.

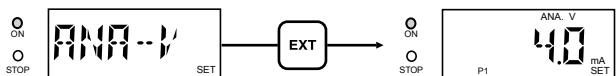

## 5 Push the DISP key and enter a stroke rate at P1.

- A stroke rate increases/decreases as pushing the UP/DOWN keys.
- Press and hold either key for three seconds for quick change. Quick change stops at 0 or 100%. 0 or 100% skips to 100 or 0% when the key is released and pushed once.

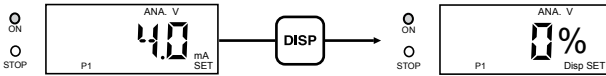

## 6 Push the DISP key and enter a current value at P2.

- A current value increases/decreases as pushing the UP/DOWN keys.
- Press and hold either key for three seconds for quick change. Quick change stops at 0.0 or 20.0mA. 0.0 or 20.0mA skips to 20.0 or 0.0mA when the key is released and pushed once.

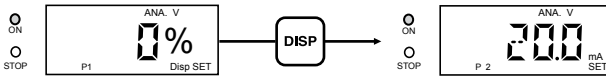

## 7 Push the DISP key and enter a stroke rate at P2.

- A stroke rate increases/decreases as pushing the UP/DOWN keys.
- Press and hold either key for three seconds for quick change. Quick change stops at 0 or 100%. 0 or 100% skips to 100 or 0% when the key is released and pushed once.

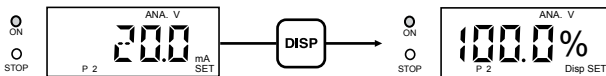

## 8 Push the EXT key to return to the EXT mode selection.

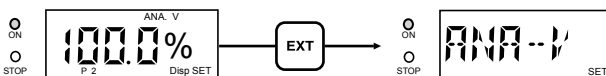

## 9 Push the start/stop key to return to EXT mode.

The pump starts to run in proportional control according to the ANA-V programming.

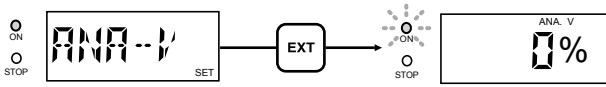

## ANA-R programming

Select "ANA-V" or "ANA-R" in USER mode. See page 72.

### 1 Enter EXT mode.

Push the EXT key to move from manual mode to EXT mode.

\*Push the start/stop key and stop the pump when it is running. Then call up EXT mode.

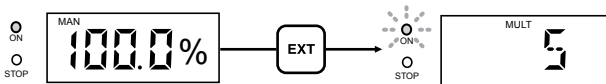

### 2 Press and hold the EXT key for one second and enter the EXT mode selection.

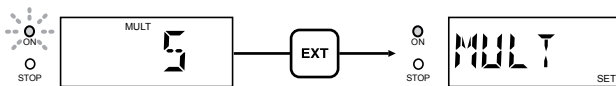

### 3 Select "ANA-R" (Analogue rigid).

Scroll through the EXT mode selection by the UP and DOWN keys.

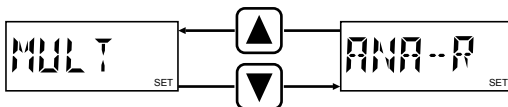

#### 4 Push the EXT key and select a preset program.

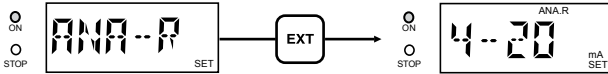

Scroll through the ANA-R programming routine by the UP and DOWN keys.

#### 5 Push the EXT key to return to the EXT mode selection.

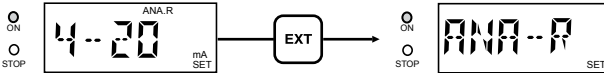

#### 6 Push the start/stop key to enter EXT mode.

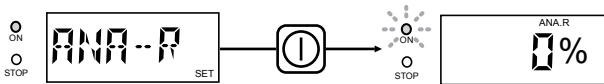

The pump starts to run in proportional control according to the ANA-R programming.

## User mode

The following features can be programmed. Get access to User mode via the wait state in the manual mode.

- **STOP function**

The pump stops running while receiving the external signal via the STOP terminal.

- **Pre-STOP function**

The STOP LED lights orange while the pump receiving the external signal via the Pre-STOP terminal. The pump does not stop running.

- **OUTPUT function**

The pump sends out signals via the OUTPUT terminal in sync with pump shots or the STOP signal.

- **ANA-V-R selection**

Select either "ANA-V" or "ANA-R" for the EXT mode.

- **Buffer ON/OFF selection**

Excessive external signals that are not reflected to the MULT or DIV operation can be stored. Activate or inactivate the buffer.

- **PIN number entry**

A PIN is required to release a keypad lock state.

### NOTE

The ANA-V-R selection is available only when "ANA-V" or "ANA-R" has been selected in the EXT mode selection. The Buffer ON/OFF selection is available only when "DIV" or "MULT" has been selected.

#### EXT mode selection

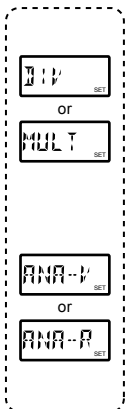

#### User mode

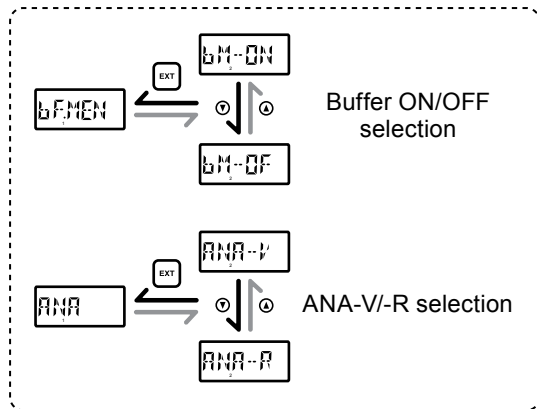



## ■ STOP/Pre-STOP function

The start/stop of the pump operation can be controlled by the external stop signal.

- **When "NOR. OP" is selected:**

The pump stops while receiving the stop signal.

- **When "NOR. CL" is selected:**

The pump runs while receiving the stop signal.

## STOP/Pre-STOP function programming

### 1 Return to the wait state in the manual mode.

Push the start/stop key to return to the manual wait state if the pump is running in manual mode or in EXT mode.



### 2 Push the EXT key for three seconds to call up the user mode.

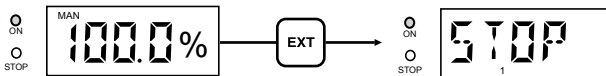

### 3 Select "STOP" or "P-STP".

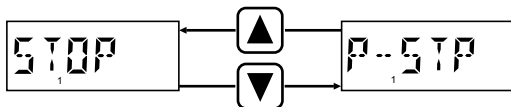

Scroll through the User mode selection by the UP and DOWN keys.

### 4 Push the EXT key.

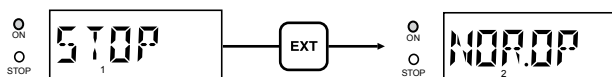

### 5 Select "NOR. OP" or "NOR. CL".

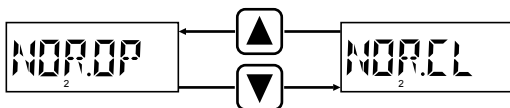

### 6 Push the start/stop key to return to manual mode.

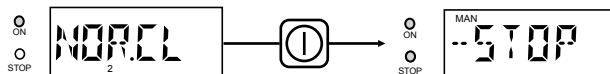

The screen indicates that the STOP function is active.

## ■ STOP/Pre-STOP function cancellation

A stop state can be cancelled if the current selection is changed.

Example) NOR.OP→NOR.CL  
NOR.CL→NOR.OP

### 1 Call up "-STOP" screen.

If the screen shows "STOP" in the manual or EXT mode, push the start/stop key.



### 2 Press and hold the EXT key for three seconds to enter User mode.

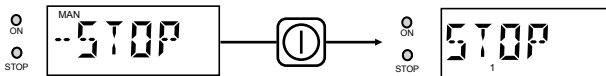

### 3 Select "STOP" or "P-STP".

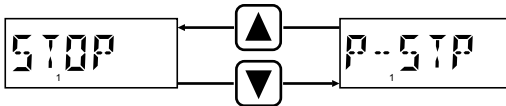

Scroll through the User mode selection by the UP and DOWN keys.

#### 4 Push the EXT key and change the current selection.

If "NOR.OP" is selected change it to "NOR.CL", and vice versa.



#### 5 Push the start/stop key to return to manual mode.

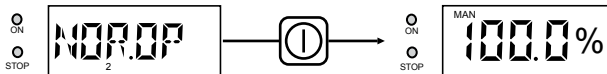

The STOP or Pre-STOP function now has been cancelled.

## ■ OUTPUT function

### • When "OUT"→"SPM" is selected:

The pump sends the OUTPUT signal at each shot while running.

### • When "OUT"→"STOP" is selected:

- The pump sends the OUTPUT signal while receiving the STOP signal (with the setting of operation stop at STOP signal input).
- The pump sends the OUTPUT signal while receiving no STOP signal (with the setting of operation resumption at STOP signal input).

## 1 Return to the wait state in the manual mode.

Push the start/stop key to return to the manual wait state if the pump is running in manual mode or in EXT mode.



## 2 Push the EXT key for three seconds to call up the user mode.

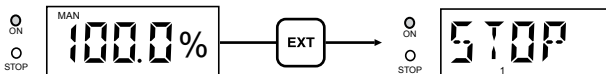

## 3 Select "OUT".

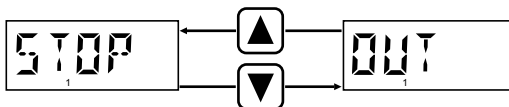

Scroll through the User mode selection by the UP and DOWN keys.

#### 4 Push the EXT key.

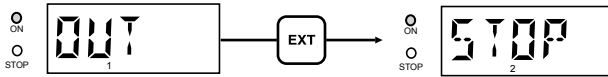

#### 5 Select "STOP" or "SPM".

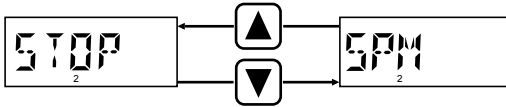

#### 6 Push the start/stop key to return to manual mode.

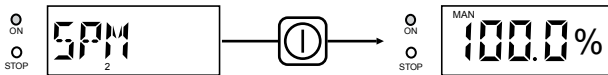

The programming has now been reflected to the pump operation.

## ■ ANA-V/-R selection

### • When "ANA-R" is selected:

The preset proportional control programs of "4-20", "20-4", "0-20" and "20-0" are available.

### • When "ANA-V" is selected:

A proportional control pattern can be newly programmed.

#### NOTE

A default setting is "ANA-R".

## 1 Return to the wait state in the manual mode.

Push the start/stop key to return to the manual wait state if the pump is running in manual mode or in EXT mode.



## 2 Push the EXT key for three seconds to call up the user mode.

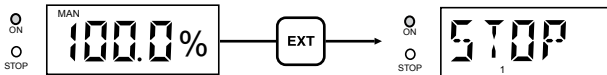

## 3 Select "ANA".

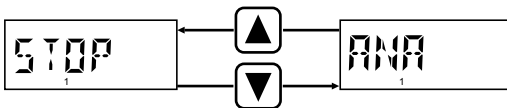

Scroll through the User mode selection by the UP and DOWN keys.

#### 4 Push the EXT key.

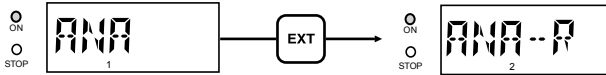

#### 5 Select "ANA-R" or "ANA-V".

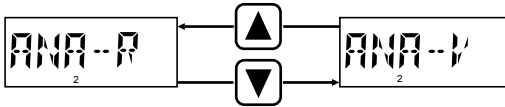

#### 6 Push the start/stop key to return to manual mode.

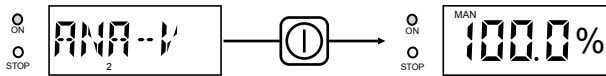

The programming has now been reflected to the pump operation.



■ **Buffer ON/OFF selection**

• **When "bM-ON" is selected:**

Excessive external signals that are not reflected to the MULT or DIV operation can be stored.

• **When "bM-OFF" is selected:**

Excessive external signals are not stored.

NOTE

A default setting is "bM-OFF".

**1 Return to the wait state in the manual mode.**

Push the start/stop key to return to the manual wait state if the pump is running in manual mode or in EXT mode.



**2 Push the EXT key for three seconds to call up the user mode.**

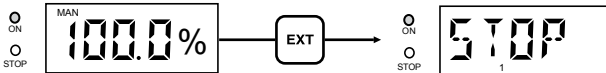

**3 Select "bF.MEM".**

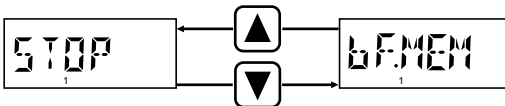

Scroll through the User mode selection by the UP and DOWN keys.

#### 4 Push the EXT key.

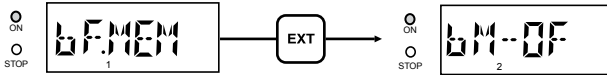

#### 5 Select "bM-ON" or "bM-OF".

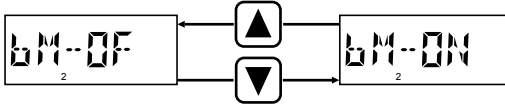

#### 6 Push the start/stop key to return to manual mode.

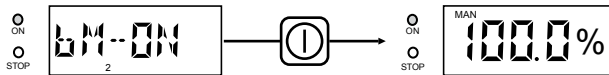

The programming has now been reflected to the pump operation.

\*The pump can run up to 65535 shots by the stored excessive signals.

## ■ PIN number entry

A PIN is required to release a keypad lock state.

NOTE

A default setting is "bM-OF".

### 1 Return to the wait state in the manual mode.

Push the start/stop key to return to the manual wait state if the pump is running in manual mode or in EXT mode.



### 2 Push the EXT key for three seconds to call up the user mode.

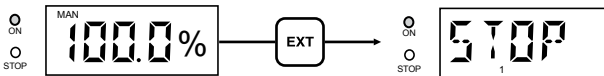

### 3 Select "CODE".

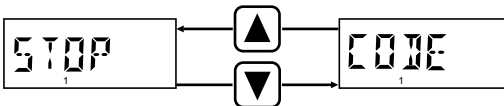

Scroll through the User mode selection by the UP and DOWN keys.

## 4 Push the EXT key.

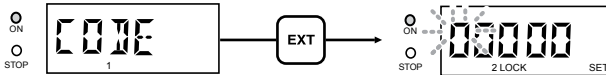

## 5 Use the UP and DOWN keys to create PIN number.

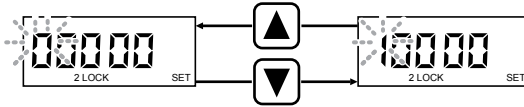

Shift to the next digit by pushing the DISP key.

\*A default PIN number is "00000".

## 6 Push the start/stop key to return to manual mode.

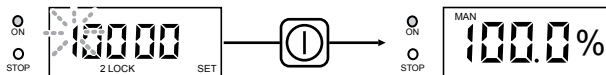

The programming has now been entered.

\*Pushing the EXT key, the programming is cancelled.

# Keypad lock

---

Keypad lock can be active in the following states for the prevention of erroneous key operation.

## Manual mode

Wait state



During operation



## EXT mode

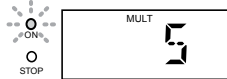

## NOTE

---

- Any key operation is not acceptable when the keypad lock is active. In an emergency, unplug the pump or enter the external signal via the STOP terminal to stop operation. If the pump is unplugged, a keypad lock state is recalled when the pump is turned on.
  - Pressing the start/stop key for three seconds, keypad lock becomes active even when the pump is receiving the STOP signal. Note that "STOP" or "-STOP" indication does not change but key operation is not accepted. Keypad lock indication appears when the STOP signal is released with "M-ON" or inputted with "M-OFF".
-

## ■ Keypad lock activation

### 1 Press and hold the start/stop key for more than three seconds.

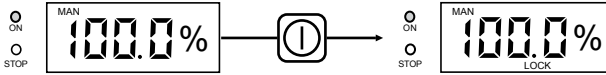

"LOCK" indication appears on the screen.

## ■ Keypad lock release

### 1 Push the EXT key once.

Enter the PIN number.

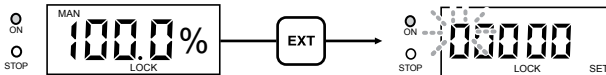

Shift to the next digit by pushing the DISP key.

\*A default PIN number is "00000".

### 2 Push the EXT key once again.

The keypad lock state is released.

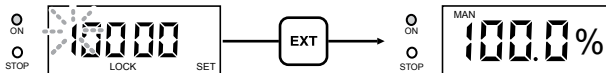

### 3 Pause/Resume operation

- To stop the pump in the keypad lock state, press and hold the start/stop key for three seconds.
- To resume operation in the keypad lock state, push the start/stop key once.

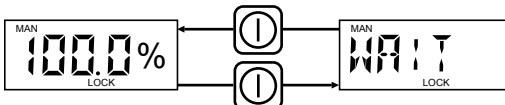

## Calibration mode

---

Entering a flow rate per shot, operation can be monitored in GPH, L/h or mL/m.

- 1 Run the pump in an actual operating condition and measure the flow for one minute.**

- 2 Return to the wait state in the manual mode.**

Push the start/stop key to return to the manual wait state if the pump is running in manual mode or in EXT mode.



- 3 Press and hold the DISP key for three seconds to call up the calibration mode.**

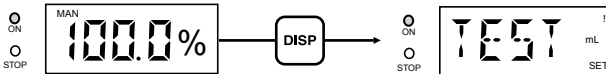

- 4 Push the DISP key once to call up a flow entry screen.**

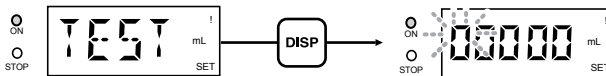

## 5 Enter the measured flow.

Shift to the next digit by pushing the DISP key.

\*Pushing the EXT key, the programming is cancelled.

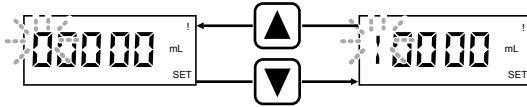

## 6 Push the start stop key to return to the wait state.

The programming is stored as "SAVE" indication appears on the screen. The maximum flow can be checked at each unit.

\*Always try to change a flow rate by stroke rate. Changing the stroke length, the flow rate per shot is changed.

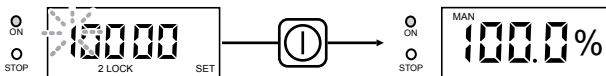

## Unit change

*GPH, L/h or mL/m cycles through every time the DISP key is pushed. To display the maximum flow rate at each unit, follow the above calibration procedure.*

## spm indication

*The screen shows an actual spm in operation when both the EXT and DOWN keys are pressed for 3 seconds. 0spm will be shown after the pump has stopped.*



# Maintenance

***This section describes troubleshooting, inspection, wear part replacement, exploded views and specifications.***

## **I Important**

- Follow instructions in this manual for replacement of wear parts. Do not disassemble the pump beyond the extent of the instructions.
- Always wear protective clothing such as an eye protection, chemical resistant gloves, a mask and a face shield during disassembly, assembly or maintenance work. The specific solution will dictate the degree of protection. Refer to MSDS precautions from the solution supplier.
- Risk of electrical shock. Be sure to turn off power to stop the pump and related devices before service is performed.

## **Before unplugging the pump**

Always stop the pump by key operation. And wait for three seconds before unplugging the pump. Otherwise, the last key operation to stop the pump may not be put in memory. In this case the pump unintentionally starts to run as powered on, discharging liquid.

---

## NOTE

- We do not assure material suitability in specified application and are not responsible for any failure due to corrosion or erosion.
  - Contact us or your nearest distributor for repair or contact a manufacturer of the host machine which our product is built in.
  - Be sure to drain chemicals and clean the inside of the pump before return so that a harmful chemical does not spill out in transit.
-

## Troubleshooting

First check the following points. If the following measures do not help remove problems, contact us or your nearest distributor.

States	Possible causes	Solutions
The pump does not run. (LED does not light. Blank screen.)	Power voltage is too low.	<ul style="list-style-type: none"> <li>• Observe the allowable voltage range of 90-264VAC</li> </ul>
	The pump is not powered.	<ul style="list-style-type: none"> <li>• Check the switch if it is installed.</li> <li>• Correct wiring.</li> <li>• Replace a breaking wire to new one.</li> </ul>
Liquid can not be pumped up.	Air lock in the pump	<ul style="list-style-type: none"> <li>• Expel air. See page 43.</li> </ul>
	Stroke length is too short.	<ul style="list-style-type: none"> <li>• Run the pump at 100% stroke length and adjust it to proper length.</li> </ul>
	Air ingress through suction line.	<ul style="list-style-type: none"> <li>• Correct tubing.</li> </ul>
	A valve set is installed upside down.	<ul style="list-style-type: none"> <li>• Reinstall the valve set.</li> </ul>
	Valve gaskets are not installed.	<ul style="list-style-type: none"> <li>• Install valve gaskets.</li> </ul>
	Foreign matters are stuck in the pump head valves.	<ul style="list-style-type: none"> <li>• Dismantle, inspect and clean the valves. Replace as necessary.</li> </ul>
	A ball valve is stuck on a valve seat.	<ul style="list-style-type: none"> <li>• Dismantle, inspect and clean the valve. Replace as necessary.</li> </ul>
A flow rate fluctuates.	Air stays in the pump head.	<ul style="list-style-type: none"> <li>• Expel air. See page 43.</li> </ul>
	Overfeeding occurs.	<ul style="list-style-type: none"> <li>• Mount a check valve. See page 33.</li> </ul>
	Foreign matters are stuck in the pump head valves.	<ul style="list-style-type: none"> <li>• Dismantle, inspect and clean the valves. Replace as necessary.</li> </ul>
	Diaphragm is broken.	<ul style="list-style-type: none"> <li>• Replace diaphragm.</li> </ul>
	Pressure fluctuates at an injection point.	<ul style="list-style-type: none"> <li>• Maintain a pressure constant at an injection point by optimizing piping or by relocating the point.</li> </ul>

States	Possible causes	Solutions
Liquid leaks.	Loose fit of the fitting or the air vent body	• Retighten them.
	Loose fit of the pump head	• Retighten the pump head. See page 42.
	O rings or valve gaskets are not installed.	• Install O rings and valve gaskets.
	Diaphragm is broken.	• Replace the diaphragm.
	Excessive discharge pressure	• Check that a discharge line is not closed. • Check if tubing is not clogged.
Key operation is ineffective.	Keypads are locked.	• Release the keypad lock.
The pump does not run.	The pump is in a wait state.	• Enter the pump into an operation mode.
	The pump has not received the external signal in the EXT mode.	• Check wiring.
	EXT mode programming has not finished.	• Complete EXT mode programming.
The pump does not receive the external signal.	The signal has not been sent to the pump.	• Check wiring.
The pump does not store EXT mode programming.	EXT mode programming has not been stored to the pump.	• Push the start/stop key after programming.

## Inspection

Perform daily and periodic inspection to keep pump performance and safety.

### Daily inspection

Check the following points. Upon sensing abnormality, stop operation immediately and remove problems according to "Troubleshooting".

When wear parts come to the life limit, replace them with new ones. Contact us or your nearest distributor for detail.

No.	States	Points to be checked	How to check
1	Pumping	• If liquid is pumped.	Flow meter or visual inspection
		• If the suction and discharge pressure are normal.	Check specifications.
		• If liquid is deteriorated, crystallized or settled?	Visual or audio inspection
2	Noise and vibration	• If abnormal noise or vibration occurs. They are signs of abnormal operation.	Visual or audio inspection
3	Air ingress from pump head joints and a suction line	• If leakage occurs. • If pumped liquid includes air bubbles, check lines for leakage and retighten as necessary.	Visual or audio inspection

### Periodic inspection

Retighten the pump head mounting bolts evenly to the following torque in diagonal order.

\*Mounting bolts may loosen in operation. How fast the bolts start to loosen is depending on operating conditions.

#### Tightening torque

Model code	Torque	Bolts
EWN-B09•11•16•21	19 lb-in	M4 Hex. socket head bolt
EWN-B31	22.6 lb-in	M4 Hex. socket head bolt
EWN-C16•21	19 lb-in	M4 Hex. socket head bolt
EWN-C31	22.6 lb-in	M4 Hex. socket head bolt
EWN-C36	22.6 lb-in	M5 Hex. socket head bolt

\*A hexagon wrench can be used for a torque wrench. See page 43.

# Wear part replacement

To run the pump for a long period, wear parts need to be replaced periodically. It is recommended that the following parts are always stocked for immediate replacement. Contact us or your nearest distributor for detail.

## ! Precautions

- Solution in the discharge line may be under pressure. Release the pressure from the discharge line before disconnecting plumbing or disassembly of the pump to avoid solution spray.
- Rinse wet ends thoroughly with tap water.
- Each time the pump head is dismantled, replace the diaphragm, O rings, valve gaskets and valve sets with new ones.

## Wear part list

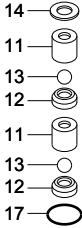
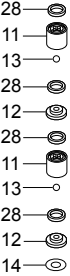
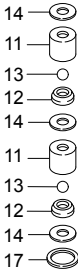
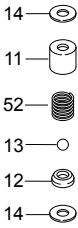
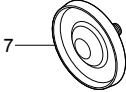
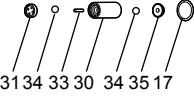
		Parts				# of parts	Estimated life
Pump	Valve set	VC•VH•VE•PC•PH•PE•TC 	SH 	FC 	P6 	2 sets	8000 hours
	Diaphragm					1	
	Automatic air vent valve set					1	

\*The high pressure types have a rear diaphragm sheet on the back side of the diaphragm.  
 \*Wear part duration varies with the pressure, temperature and characteristics of liquid.  
 \*The estimated life is calculated based on the continuous operation with clean water at ambient temperature.

## **Before replacement**

---

*First release pressure from the pump head.*

**1** Stop the pump operation.

**2** Rotate the adjusting screw two revolutions anticlockwise to open the air vent port.

**NOTE**

Do not rotate it three revolutions or more. Otherwise, the adjusting screw may come off with solution spray.

**3** Check that liquid comes out from the air vent port and gas/liquid pressure has been released.

**NOTE**

The pressure may not be expelled completely as long as liquid does not come out. In this case run the pump until the pressure is released.

\*The air vent port is not equipped to the FC. Install an air vent valve on a discharge line and release the pressure by opening the valve. See page 32.

## **Valve set replacement**

---

### ■ Discharge valve set dismantlement/assembly

#### **Necessary tools**

- Adjustable wrench or spanner
- 0.9 inch (21mm) box wrench
- A pair of tweezers

\*Unfix the pump base before disassembly.

- 1** Loosen the fitting nut to remove a discharge tube and an air bleed tube.

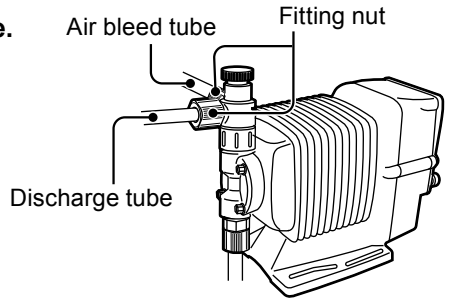

- 2** Turn the lock nut anticlockwise by an adjustable wrench and remove the air vent body A.

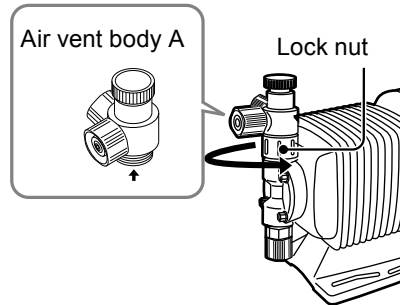

- 3** Remove the air vent body B by the 0.9 inch (21mm) box wrench.

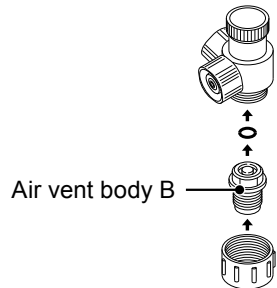

- 4** Pull out the valve set by a pair of tweezers.

**5 Place a new valve set into the pump head and screw the air vent body B through the lock nut.**

\*Be careful not to misarrange the valve set or place it upside down. Otherwise, leakage or flow rate reduction may result.

\*Do not forget to fit O rings and gaskets.

\*Keep the valve set free from dust or foreign matters.

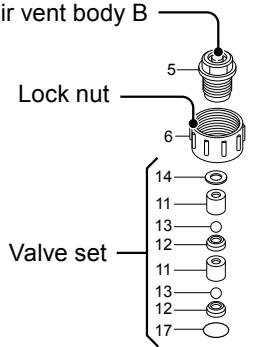

\*VC•VH•VE•PC•PH•PE

**6 Remount the air vent body A and connect tubes.**

■ Suction valve set dismantlement/assembly

NOTE

Be careful not to drop the valve set.

**1 Remove the fitting nut to remove the suction tube.**

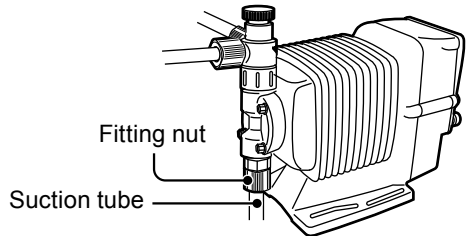

**2 Remove the fitting by an adjustable wrench or a spanner.**

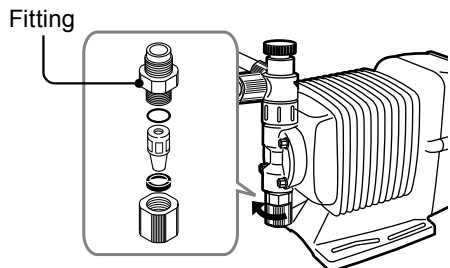



**3** Pull out the valve set by a pair of tweezers.

**4** Hand-tighten the fitting with the valve set in it into the pump head as far as it will go. Retighten it by a further 1/4 turn with an adjustable wrench or a spanner.

\*Be careful not to misarrange the valve set or place it upside down. Otherwise, leakage or flow rate reduction may result.

\*Do not forget to fit O rings and gaskets.

\*Keep the valve set free from dust or foreign matters.

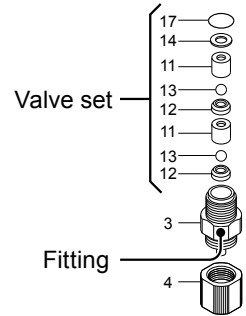

\*VC•VH•VE•PC•PH•PE•TC

**5** Reconnect the suction tube.

#### ■ Spacer set replacement (Auto degassing type)

Dismantlement/assembly of the discharge and suction valve sets are the same as above.

**1** Loosen the lock nut and remove the fitting adapter.

**2** Loosen the air vent body B and take it out of the pump head. Then pull out the spacer set.

**3** Place a new spacer set into the pump head. Screw the air vent body B into the pump head through the lock nut.

\*Do not forget to fit O rings and gaskets.

\*Keep the spacer set free from dust or foreign matters.

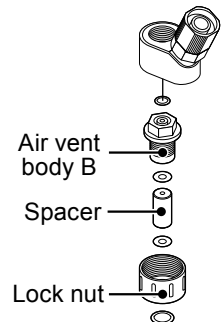

## ■ Air vent valve set replacement (Auto degassing type)

### 1 Loosen the fitting nut and remove an air bleed tube.

\*Be careful not to get wet with a residual chemical.

### 2 Loosen and remove the fitting.

### 3 Take the air vent valve set out of the fitting adapter.

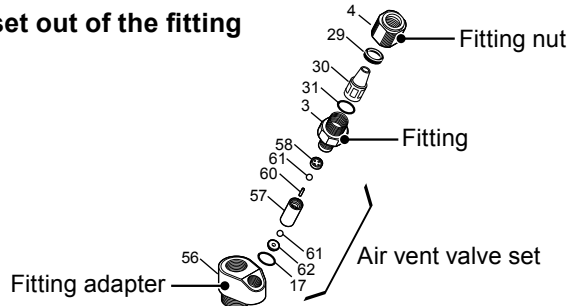

### 4 Place a new air vent valve set into the fitting and then hand-tighten it into the fitting adapter as far as it will go. Retighten the fitting by a further 1/4 turn with a spanner.

\*Note the air vent valve set has a mounting direction.  
Always mount the depressed end first.

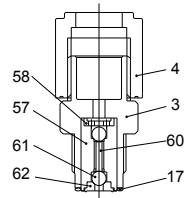

## ***Diaphragm replacement***

### **Necessary tools**

- Adjustable wrench or spanner
- Hexagon wrench
- Torque wrench

### **NOTE**

Pay attention not to lose diaphragm spacers. Always apply a proper number of diaphragm spacers. 0 or a few diaphragm spacers are inserted between the retainer and plunger for the adjustment of diaphragm location. Note that the number of diaphragm spacers varies with pump model.

**1** Run the pump and set the stroke length to 0%. Then stop the pump.

**2** Loosen the fitting nuts and remove a suction tube, a discharge tube and an air bleed tube.

For the auto degassing type, disconnect another air bleed tube from the automatic air vent valve body as well.

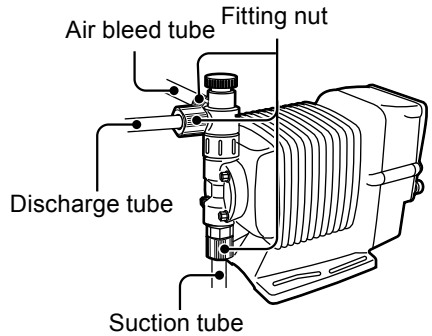

**3** Remove the pump head with a hexagon wrench.

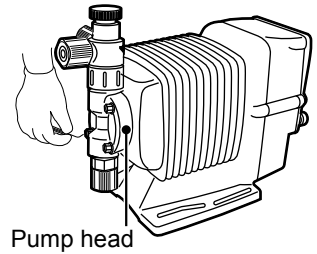

**4** Rotate and remove the diaphragm from the plunger (pump shaft).

**5** Slide a retainer and diaphragm spacer(s) onto the screw of a new diaphragm.

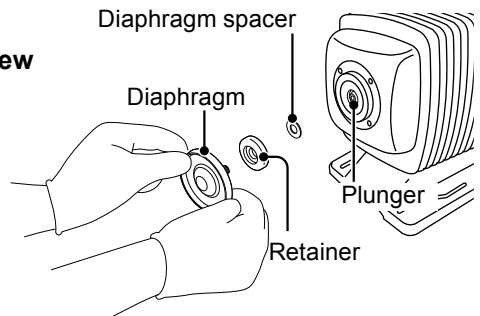

## NOTE

- Fit the retainer to the diaphragm with its round edge to the diaphragm.
- Check that the bracket spacer is in place. Refit the bracket spacer into the bracket, combining mating parts as necessary.
- The B/C-31 & -36 types do not have a bracket spacer.

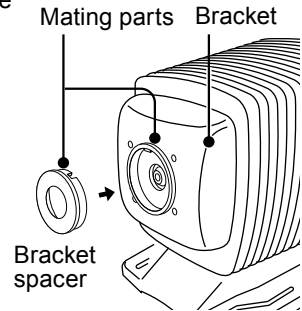

**6** Screw the new diaphragm into the plunger as far as it will go.

**7** Run the pump and set the stroke length to 100%. Then stop the pump.

**8** Mount the pump head.

Tighten the pump head fixing bolts evenly to the following torque in diagonal order.

### Tightening torque

Model code	Torque	Bolts
EWN-B09•11•16•21	19 lb-in	M4 Hex. socket head bolt
EWN-B31	22.6 lb-in	M4 Hex. socket head bolt
EWN-C16•21	19 lb-in	M4 Hex. socket head bolt
EWN-C31	22.6 lb-in	M4 Hex. socket head bolt
EWN-C36	22.6 lb-in	M5 Hex. socket head bolt

\*A hexagon wrench can be used for a torque wrench. See page 43.

# Exploded view

## Pump head, Drive unit & Control unit

The pump in the diagram below is completely dismantled. Do not dismantle the pump beyond the extent shown in this instruction manual.

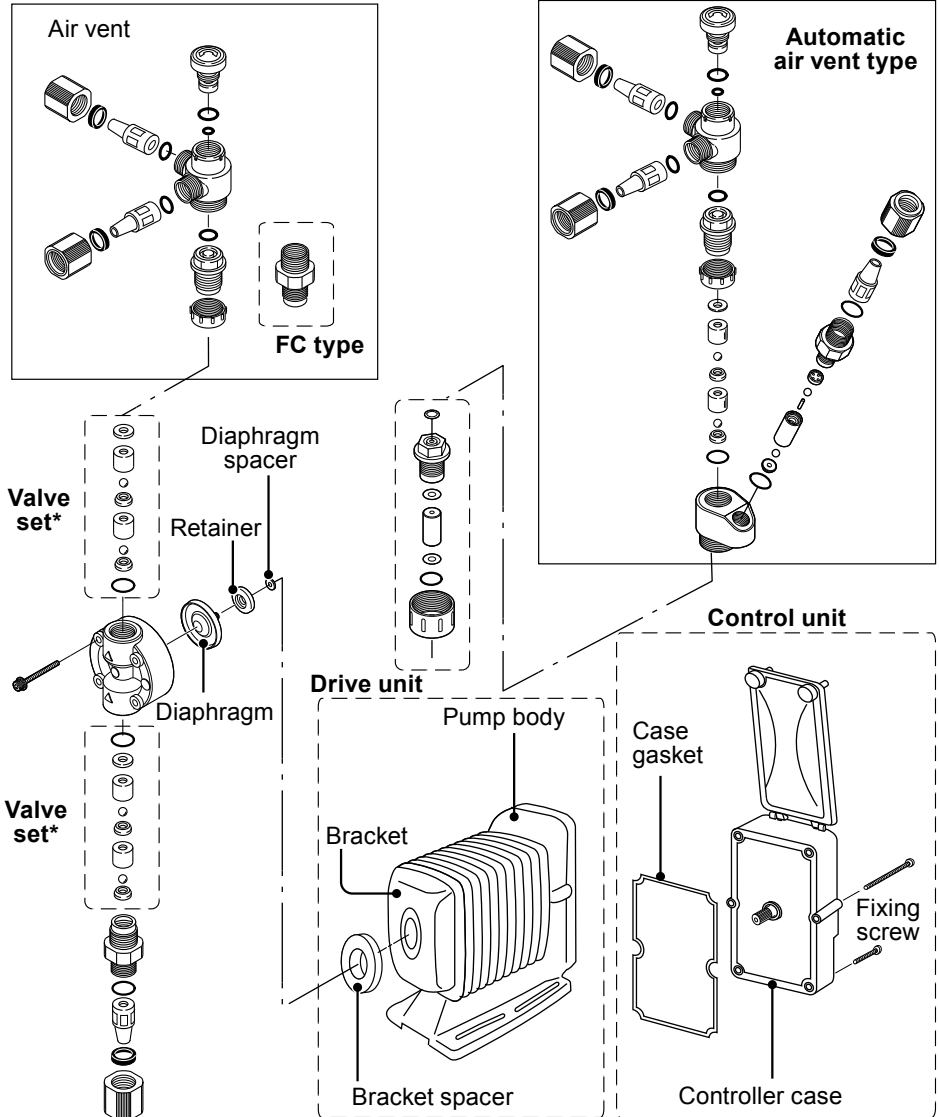

\*Wet end materials and their sizes differ with models. See "Wear part list" on page 86 for detail.

# Pump head

■ EWN-[B09•B11•B16•B21•C16•C21][VC•VH•VE•PC•PH•PE•TC]

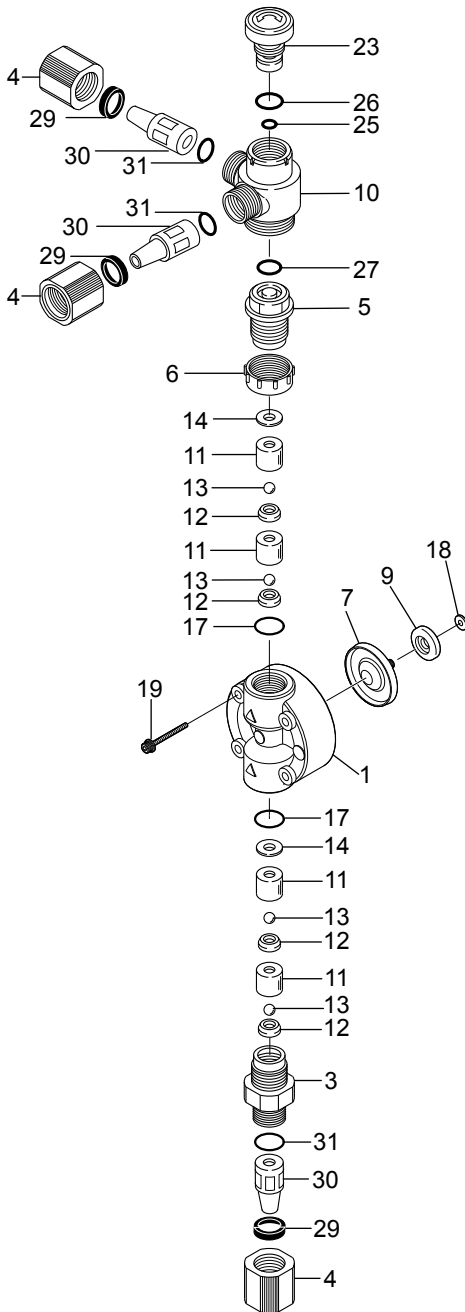

No.	Part names	# of parts
1	Pump head	1
3	Fitting	1
4	Fitting nut	3
5	Air vent body B	1
6	Lock nut	1
7	Diaphragm	1
9	Retainer	1
10	Air vent body A	1
11	Valve guide	4
12	Valve seat	4
13	Valve	4
14	Valve gasket	2
17	O ring	2
18	Diaphragm spacer	*
19	Hex. socket head bolt [PW•SW]	4
23	Adjusting screw	1
25	O ring	1
26	O ring	1
27	O ring	1
29	Hose stopper	3
30	Hose adaptor	3
31	O ring	3

\*The number of diaphragm spacers varies with pump model.

\*For the high pressure types, a rear diaphragm seat is placed between the parts 7 and 9.

■ EWN-[B31•C31•C36][VC•VH•VE•PC•PH•PE•TC]

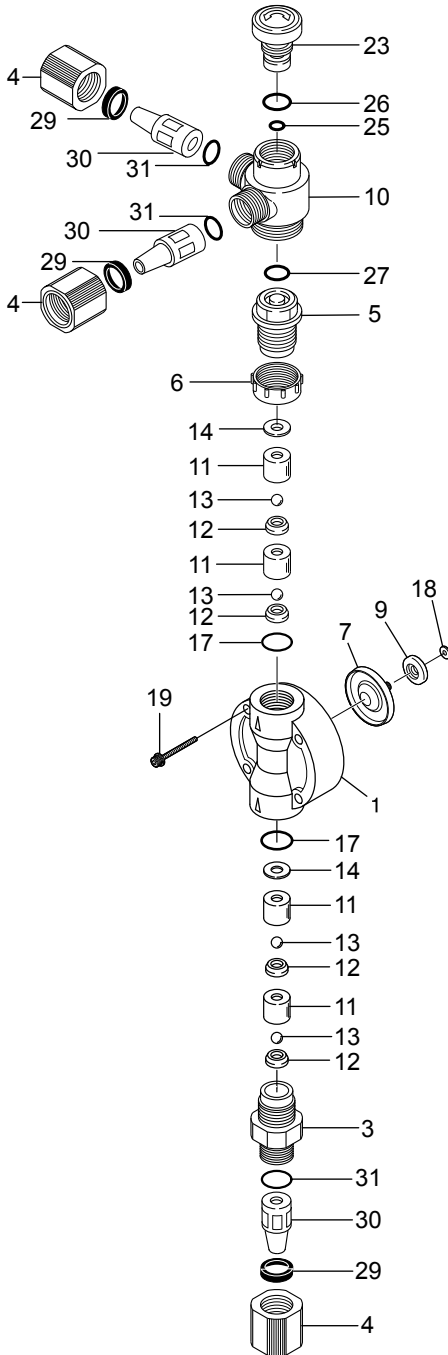

No.	Part names	# of parts
1	Pump head	1
3	Fitting	1
4	Fitting nut	3
5	Air vent body B	1
6	Lock nut	1
7	Diaphragm	1
9	Retainer	1
10	Air vent body A	1
11	Valve guide	4
12	Valve seat	4
13	Valve	4
14	Valve gasket	2
17	O ring	2
18	Diaphragm spacer	*
19	Hex. socket head bolt [PW•SW]	4
23	Adjusting screw	1
25	O ring	1
26	O ring	1
27	O ring	1
29	Hose stopper	3
30	Hose adaptor	3
31	O ring	3

\*The number of diaphragm spacers varies with pump model.

■ EWN FC

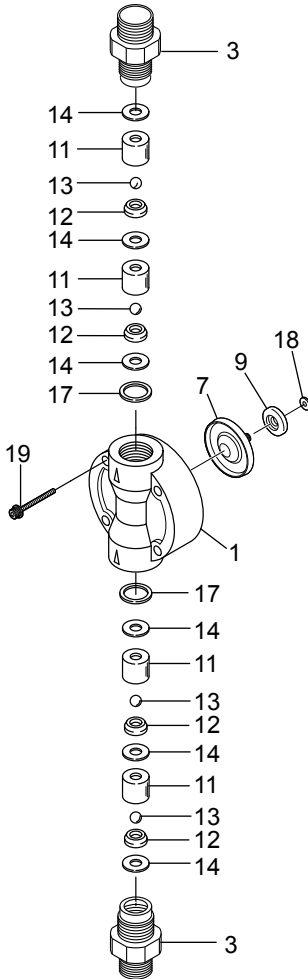

No.	Part names	# of parts
1	Pump head	1
3	Fitting	2
7	Diaphragm	1
9	Retainer	1
11	Valve guide	4
12	Valve seat	4
13	Valve	4
14	Valve gasket	6
17	Gasket	2
18	Diaphragm spacer	*
19	Hex. socket head bolt [PW•SW]	4

\*The number of diaphragm spacers varies with pump model.



■ EWN-C31 P6-V

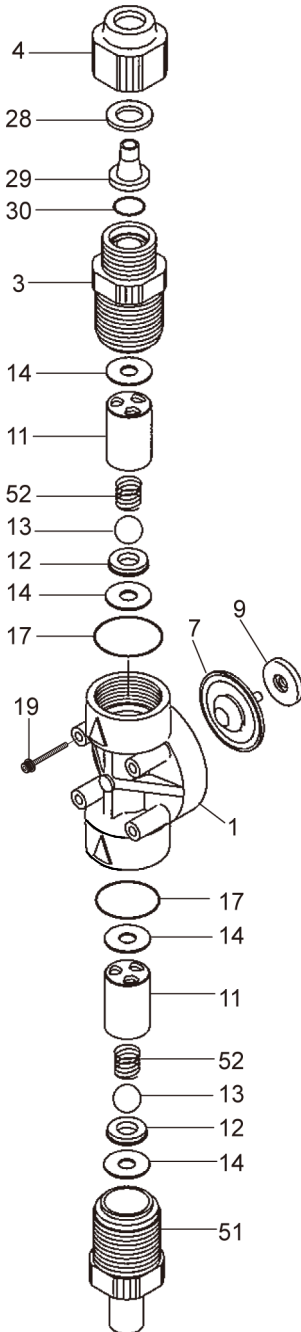

No.	Part names	# of parts
1	Pump head	1
3	Fitting	1
4	Fitting nut	1
7	Diaphragm	1
9	Retainer	1
11	Valve guide	2
12	Valve seat	2
13	Valve	2
14	Valve gasket	4
17	O ring	2
19	Hex. socket head bolt [PW•SW]	4
28	Hose stopper	1
29	Fitting spacer	1
30	O ring	1
51	Inlet	1
52	Valve spring	2

\*The number of diaphragm spacers varies with pump model.

■ EWN SH/SH-H/SH-H2

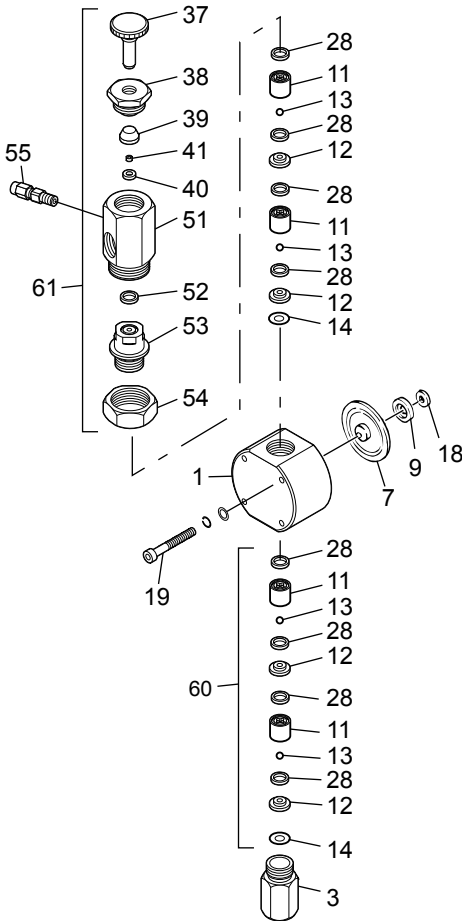

No.	Part names	# of parts
1	Pump head	1
3	Fitting	1
7	Diaphragm	1
9	Retainer	1
11	Valve guide	4
12	Valve seat	4
13	Valve	4
14	Valve gasket B	2
18	Diaphragm spacer	*
19	Hex. socket head bolt [PW•SW]	4
28	Valve gasket A	8
37	Adjusting screw	1
38	Seal nut	1
39	Seal ring	1
40	Seat	1
41	Seat ring	1
51	Air vent body A	1
52	Gasket	1
53	Air vent body B	1
54	Nut	1
55	Male connector	1

\*The number of diaphragm spacers varies with pump model.

\*For the high pressure types, a rear diaphragm sheet is placed between the parts 7 and 9.

## ■ EWN with an Automatic air vent

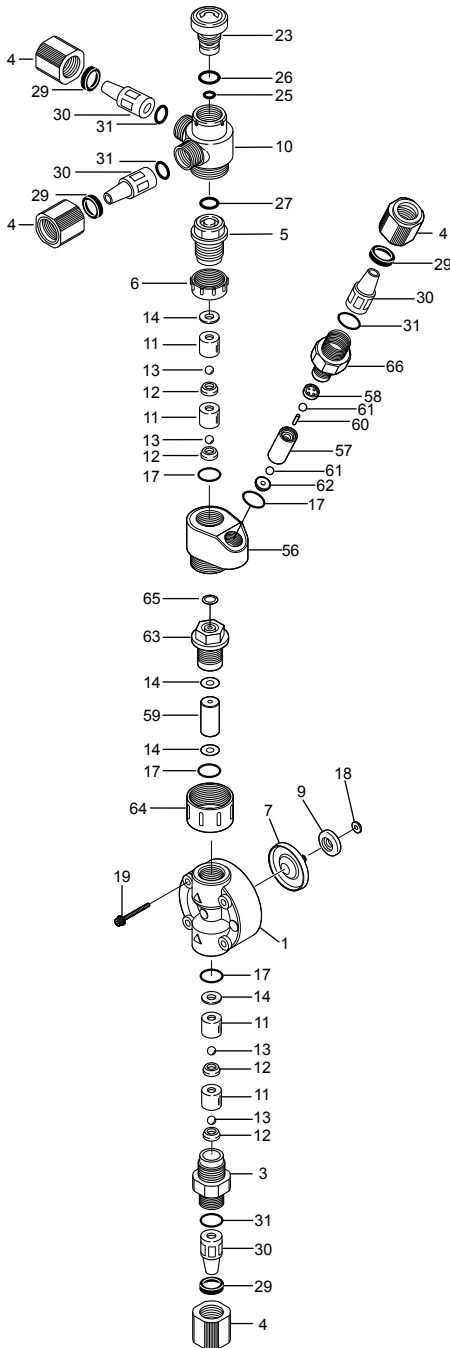

No.	Part names	# of parts
1	Pump head	1
2	Bracket	1
3	Fitting	2
4	Fitting nut	4
5	Air vent body B	1
6	Lock nut	1
7	Diaphragm	1
9	Retainer	1
10	Air vent body A	1
11	Valve guide	4
12	Valve seat	4
13	Valve	4
14	Valve gasket	4
17	O ring	4
18	Diaphragm spacer	1
19	Hex. sock. cap bolt [PW•SW]	4
22	Diaphragm seal	1
23	Adjusting screw	1
24	Name plate	1
25	O ring	1
26	O ring	1
27	O ring	1
28	Bracket spacer	1
29	Hose stopper	4
30	Hose adapter	4
31	O ring	4
56	Fitting adapter	1
57	Air vent valve guide A	1
58	Air vent valve guide B	1
59	Spacer	1
60	Separate pin	1
61	Valve	2
62	Valve seat	1
63	Air vent body B	1
64	Lock nut	1
65	O ring	1
66	Air vent fitting	1

## Specifications/Outer dimensions

### Specifications

Information in this section is subject to change without notice.

#### ■ Pump unit

#### VC•VH•VE•PC•PH•PE

Model code	Flow rate GPH (ml/min)	Discharge pressure PSI (MPa)	Stroke length % (mm)	Stroke rate % (spm)	Power con- sumption W	Current value A	Weight lb
EWN-B11	0.6 (38)	145.0 (0.1)	50-100 (0.5-1.0)	0.1-100 (1-360)	20	0.8	6.2
EWN-B16	1.0 (65)	101.5 (0.7)					
EWN-B21	1.6 (100)	58.0 (0.4)					
EWN-B31	3.2 (200)	29.0 (0.2)					
EWN-C16	1.3 (80)	145.0 (1.0)	40-100 (0.5-1.25)	0.1-100 (1-360)	24	1.2	8.2
EWN-C21	2.1 (130)	101.5 (0.7)					
EWN-C31	4.3 (270)	50.8 (0.35)					
EWN-C36	6.7 (420)	29.0 (0.2)					

#### FC•SH•TC

Model code	Flow rate GPH (ml/min)	Discharge pressure PSI (MPa)	Stroke length % (mm)	Stroke rate % (spm)	Power con- sumption W	Current value A	Weight lb
EWN-B11	0.6 (38)	145.0 (0.1)	50-100 (0.5-1.0)	0.1-100 (1-360)	20	0.8	6.2
EWN-B16	1.0 (65)	101.5 (0.7)					
EWN-B21	1.6 (100)	58.0 (0.4)					
EWN-B31	3.2 (200)	29.0 (0.2)					
EWN-C16	1.3 (80)	145.0 (1.0)	40-100 (0.5-1.25)	0.1-100 (1-360)	24	1.2	8.2
EWN-C21	2.1 (130)	101.5 (0.7)					
EWN-C31	4.3 (270)	50.8 (0.35)					
EWN-C36	6.5 (410)	29.0 (0.2)					

**VC•VH•VE•PC•PH•PE (High compression type)**

Model code	Flow rate GPH (ml/min)	Discharge pressure PSI (MPa)	Stroke length % (mm)	Stroke rate % (spm)	Power con- sumption W	Current value A	Weight lb
EWN-B09	0.2 (12)	145.0 (1.0)	50-100 (0.625-1.25)	0.1-100 (1-180)	20	0.8	6.2
EWN-B11	0.4 (23)	145.0 (1.0)					
EWN-B16	0.6 (40)	101.5 (0.7)					
EWN-B21	1.0 (63)	58.0 (0.4)					
EWN-C16	0.9 (54)	145.0 (1.0)	40-100 (0.6-1.50)		24	1.2	8.2
EWN-C21	1.2 (130)	101.5 (0.7)					

**PC•PH•SH (High pressure type)**

Model code	Flow rate GPH (ml/min)	Discharge pressure PSI (MPa)	Stroke length % (mm)	Stroke rate % (spm)	Power con- sumption W	Current value A	Weight lb
EWN-B11	0.4 (25)	246.6 (1.7)	50-100 (0.5-1.0)	0.1-100 (1-240)	20	0.8	6.2
EWN-C16	0.6 (40)	246.6 (1.7)	40-100 (0.5-1.25)		24	1.2	8.2

**PC•PH•SH (High pressure type (2MPa))**

Model code	Flow rate GPH (ml/min)	Discharge pressure PSI (MPa)	Stroke length % (mm)	Stroke rate % (spm)	Power con- sumption W	Current value A	Weight lb
EWN-B11	0.3 (17)	290.1 (2.0)	70-100 (0.6-0.9)	0.1-100 (1-240)	20	0.8	6.2

**P6 (High viscosity type)**

Model code	Flow rate GPH (ml/min)	Discharge pressure PSI (MPa)	Stroke length % (mm)	Stroke rate % (spm)	Power con- sumption W	Current value A	Weight lb
EWN-C31	2.4 (150)	72.5 (0.5)	40-100 (0.5-1.25)	0.1-100 (1-240)	24	1.2	8.2

**Auto degassing type**

Model code	Flow rate GPH (ml/min)	Discharge pressure PSI (MPa)	Stroke length % (mm)	Stroke rate % (spm)	Power con- sumption W	Current value A	Weight lb
EWN-B11	0.5 (30)	145.0 (1.0)	50-100 (0.5-1.0)	0.1-100 (1-360)	20	0.8	6.4
EWN-B16	0.9 (55)	101.5 (0.7)					
EWN-C16	1.0 (65)	145.0 (1.0)	40-100 (0.5-1.25)		24	1.2	8.4
EWN-C21	1.7 (110)	101.5 (0.7)					

\*These specifications were collected at the time of our shipping inspection and based on pumping clean water at ambient temperature and rated voltage.

\*Flow rates were collected at the maximum discharge pressure, 100% stroke length and 100% stroke rate. A flow rate increases as a discharge pressure decreases.

\*Allowable room temperature: 0-40°C

\*Allowable liquid temperature: 0-40°C (0-60°C for the PC•PH•FC)

\*Allowable power voltage deviation: ±10% of the rated range

\*For the P6-V type, its flow rate was collected with clean water. The rate may change depending on liquid viscosity, and therefore is not guaranteed.

#### ■ Power cable

Conduction section area	0.824 mm <sup>2</sup> (18AWG)	Standard	SJTW
Length	2000 [mm]	Terminal treatment	American type plug

#### ■ Pump colour

Blue	Munsell colour system 7.5PB 3/8
Red	Munsell colour system 5R 3/10

## Outer dimensions

### ■ EWN-[B11•B16•B21] [VC•VH•VE] [U•U2]R

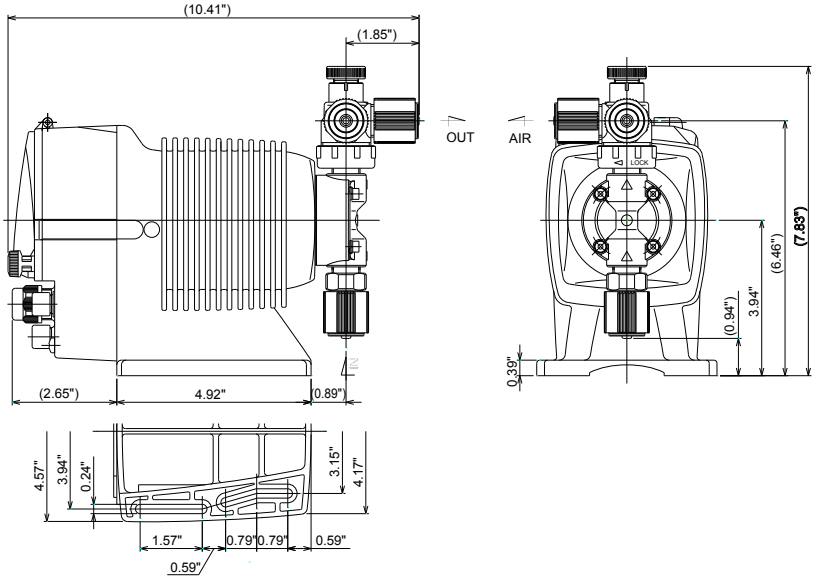

### ■ EWN-B31 [VC•VH•VE] [U•U2]R

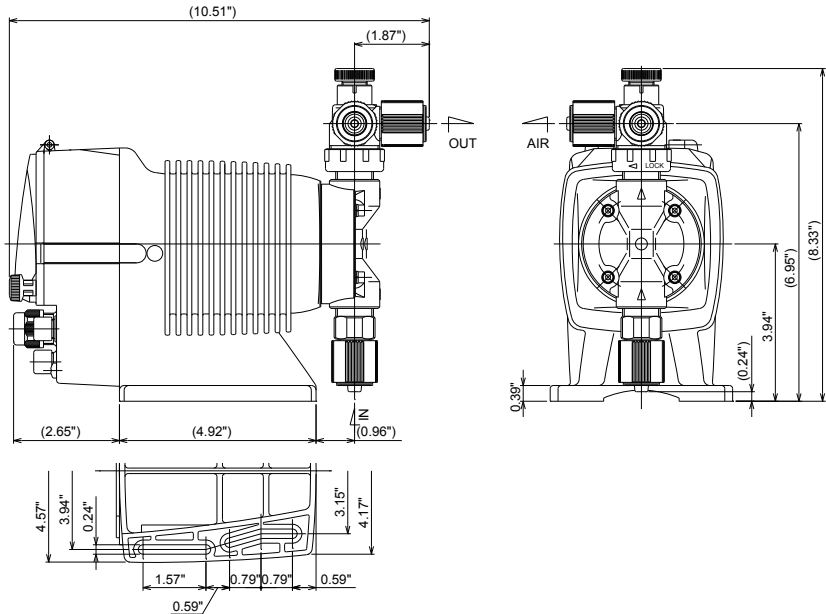

■ EWN-[C16•C21] [VC•VH•VE] [U•U2]R

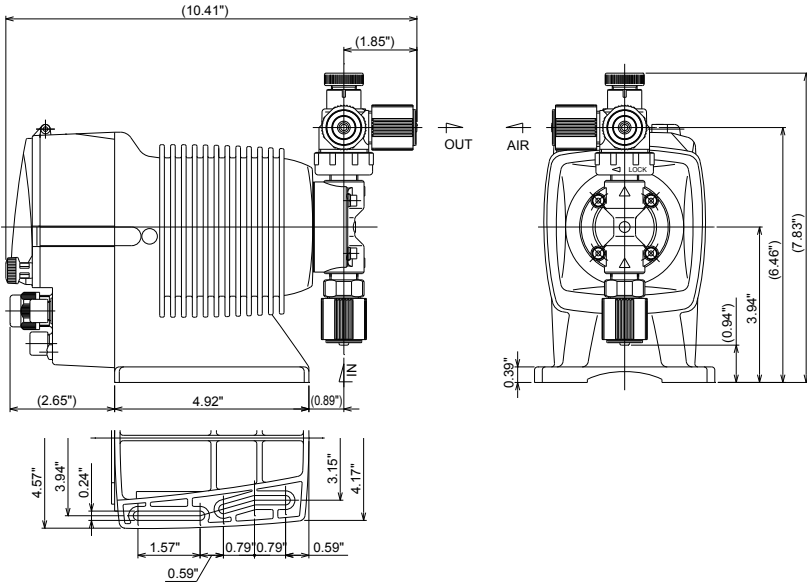

■ EWN-C31 [VC•VH•VE] [U•U2]R

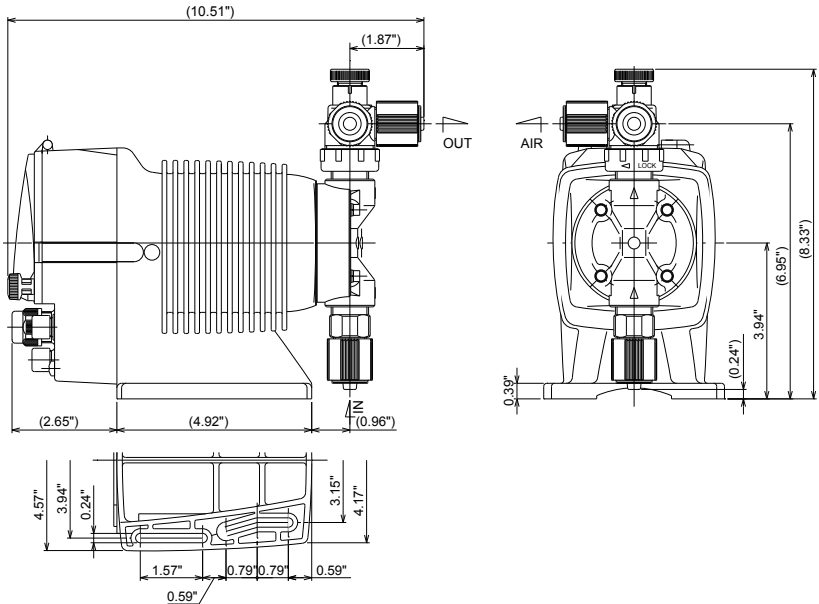



■ EWN-C36 [VC·VH·VE] [U·U2]R

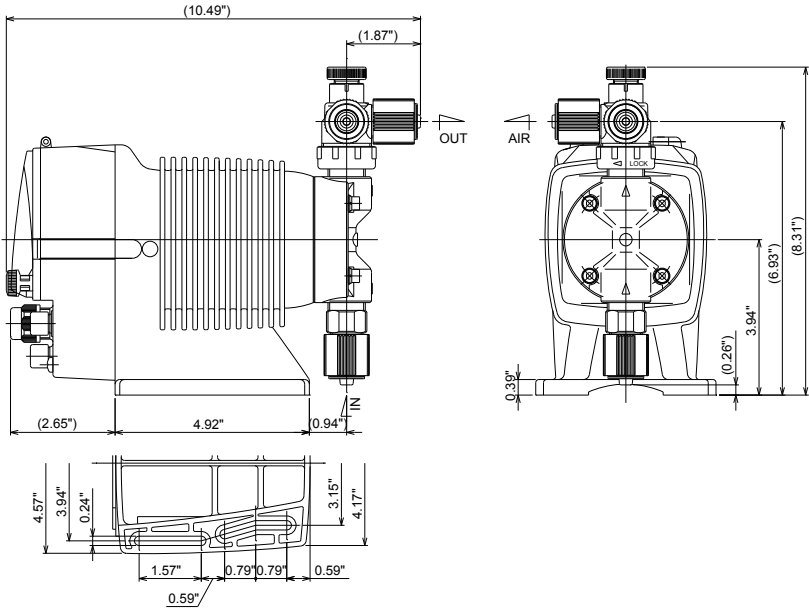

■ EWN-[B11·B16·B21] [PC·PH·PE] [U·U2]R

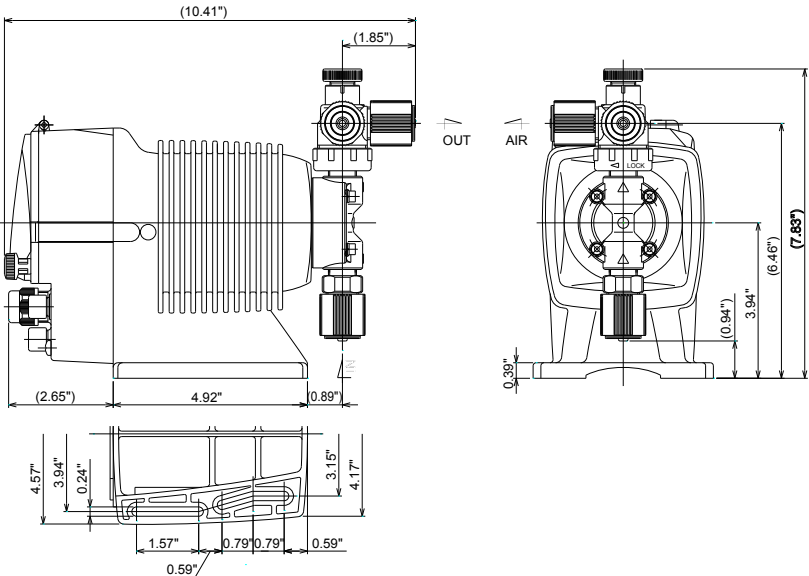

■ EWN-B31 [PC·PH·PE] [U·U2]R

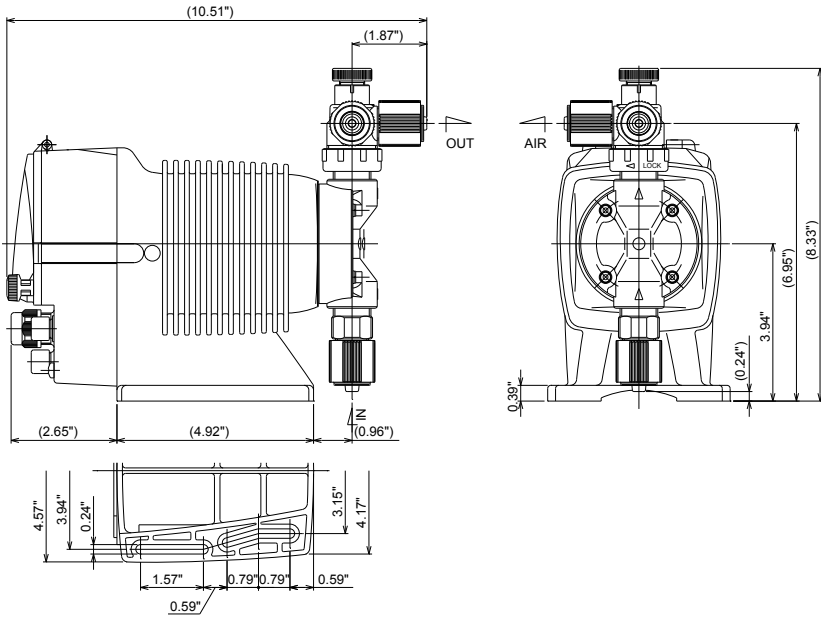

■ EWN-[C16·C21] [PC·PH·PE] [U·U2]R

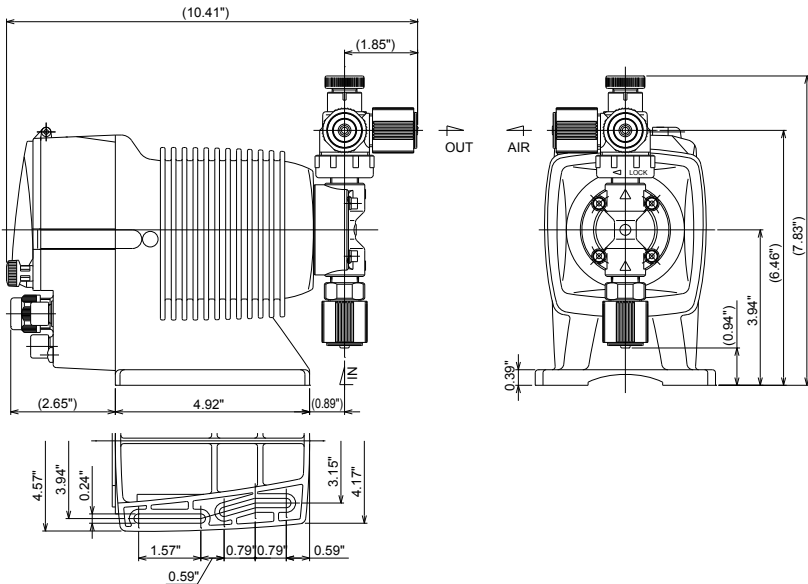

■ EWN-C31 [PC·PH·PE] [U·U2]R

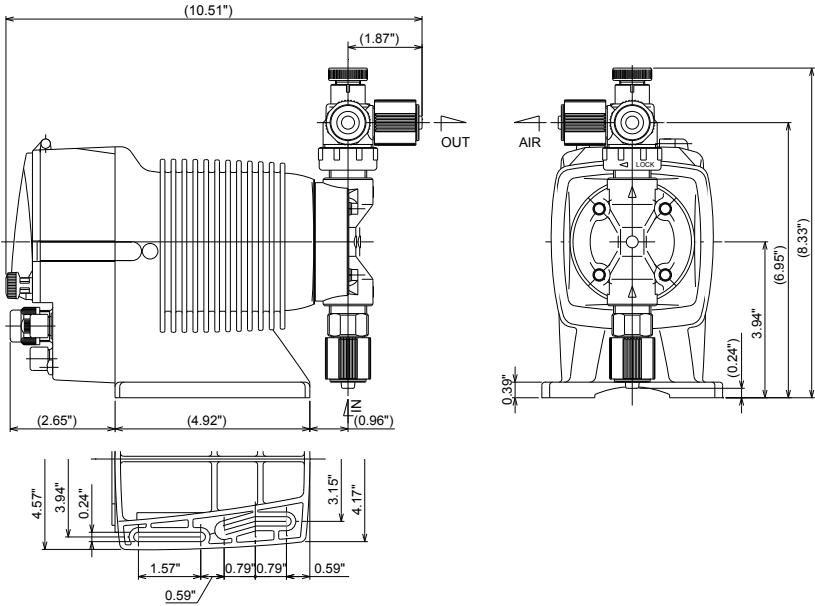

■ EWN-C36 [PC·PH·PE] [U·U2]R

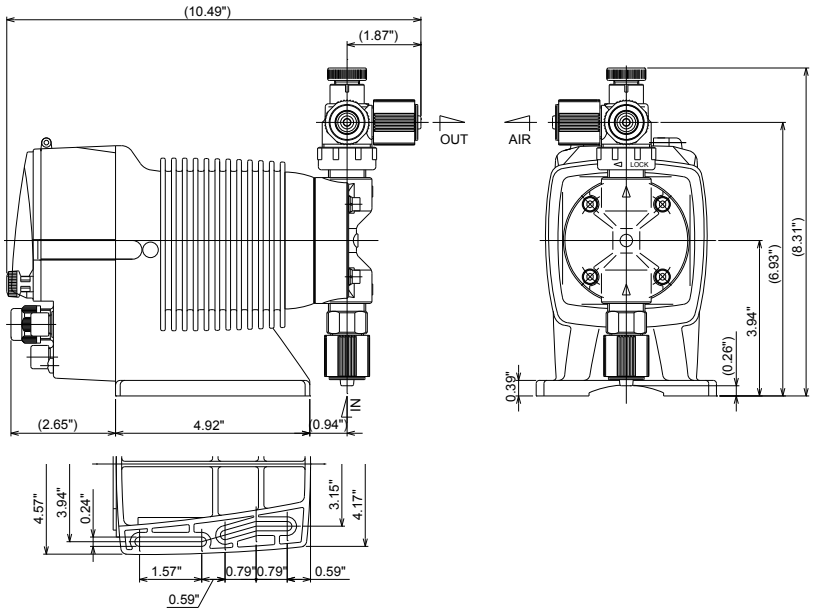

■ EWN-[B11•B16•B21] FC [U•U2]R

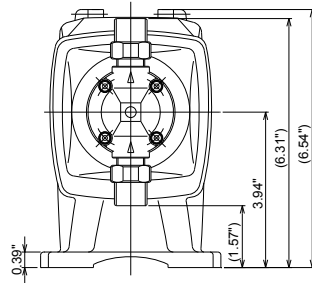
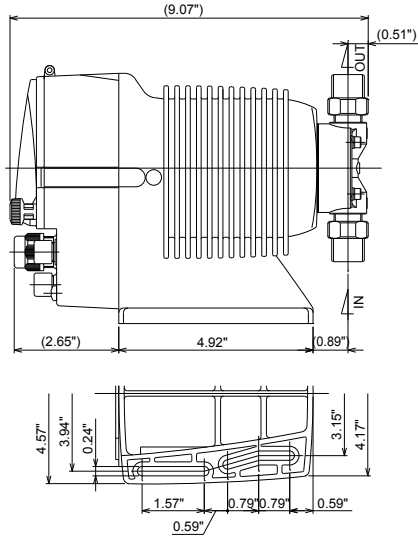

■ EWN-B31 FC [U•U2]R

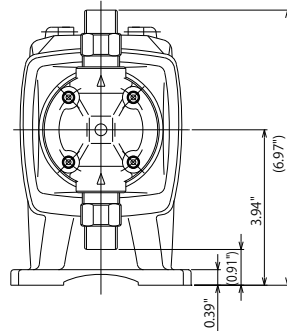
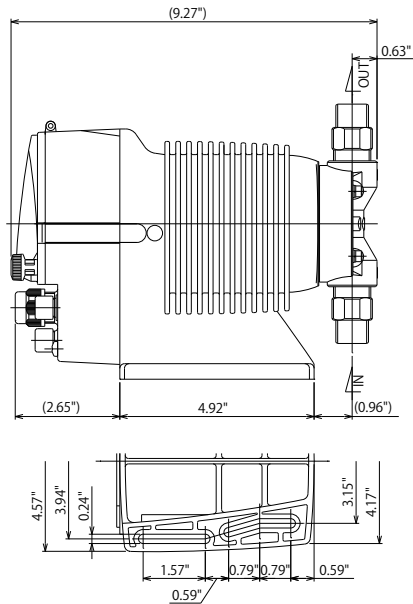

■ EWN-[C16•C21] FC [U•U2]R

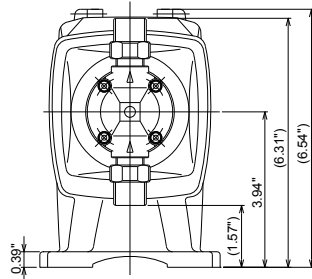
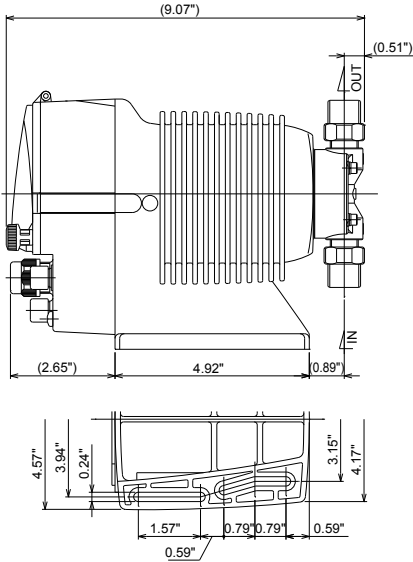

■ EWN-C31 FC [U•U2]R

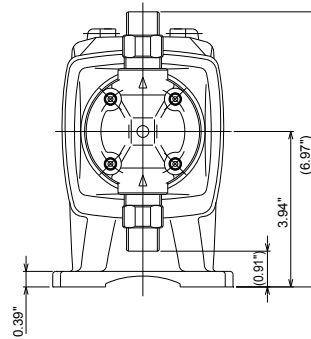
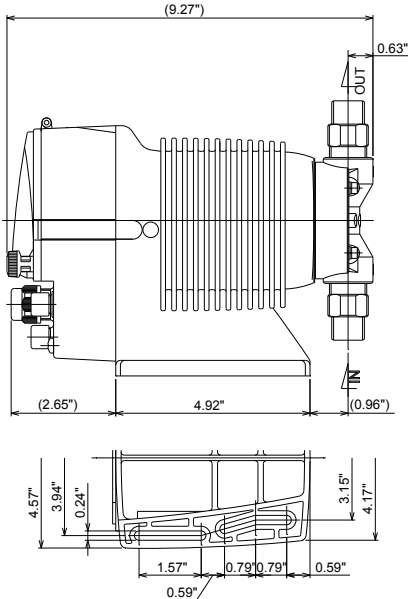

■ EWN-C36 FC [U•U2]R

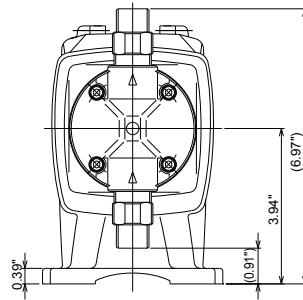
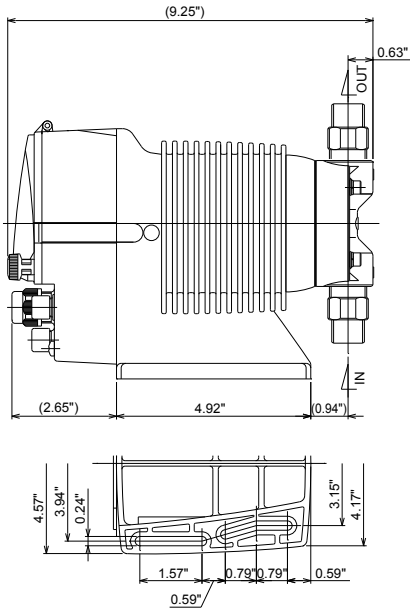

■ EWN-[B11•B16•B21] TC [U•U2]R

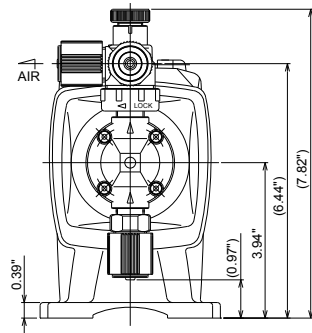
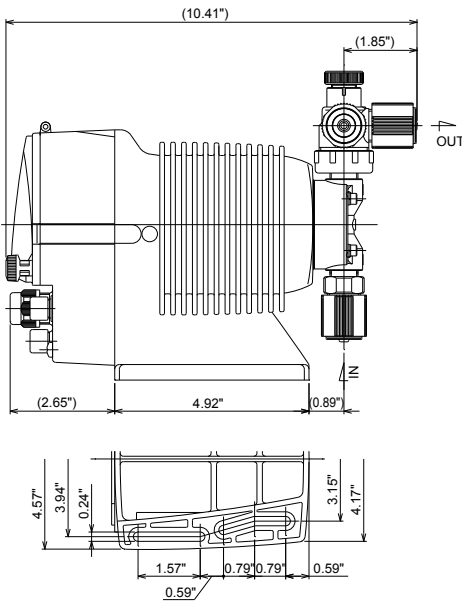

■ EWN-B31 TC [U·U2]R

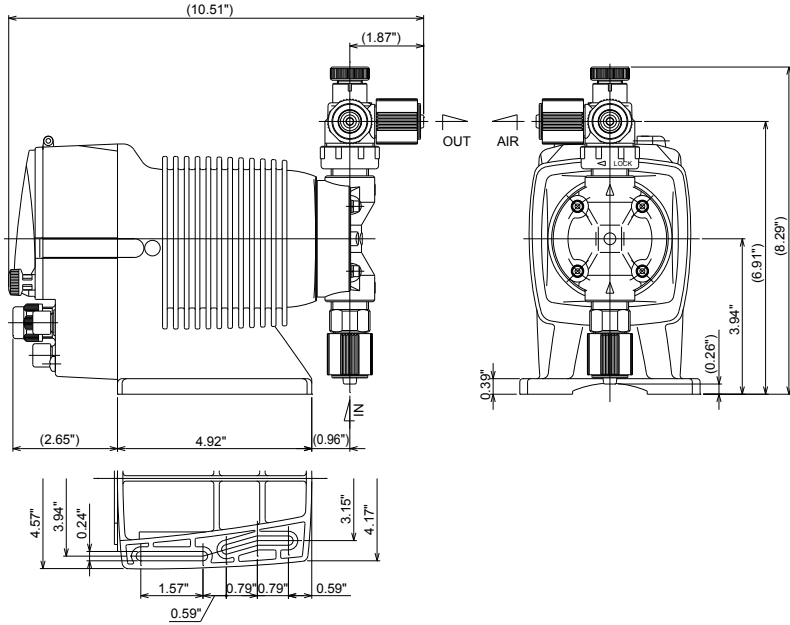

■ EWN-[C16-C21] TC [U·U2]R

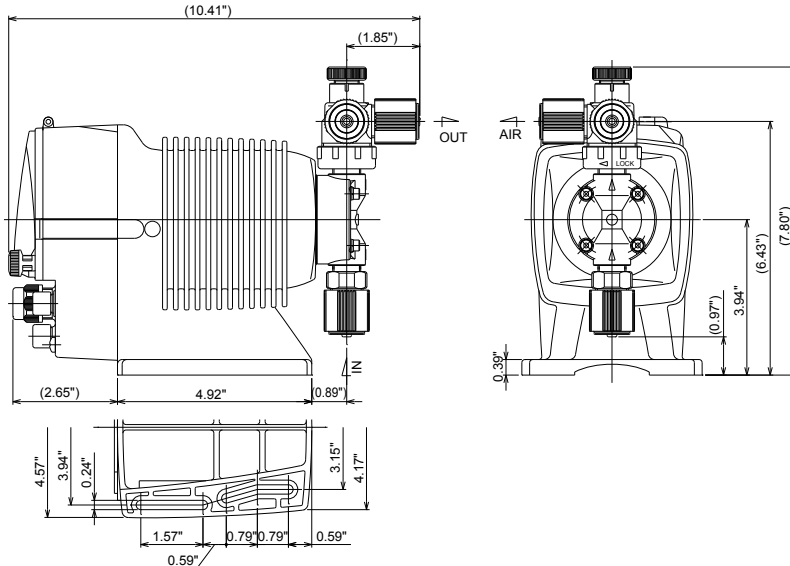

■ EWN-C31 TC [U•U2]R

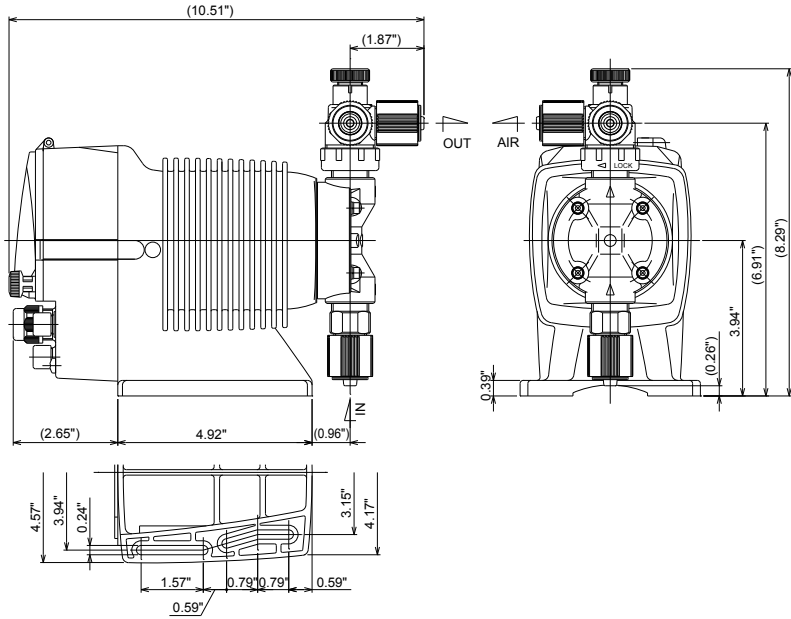

■ EWN-C36 TC [U•U2]R

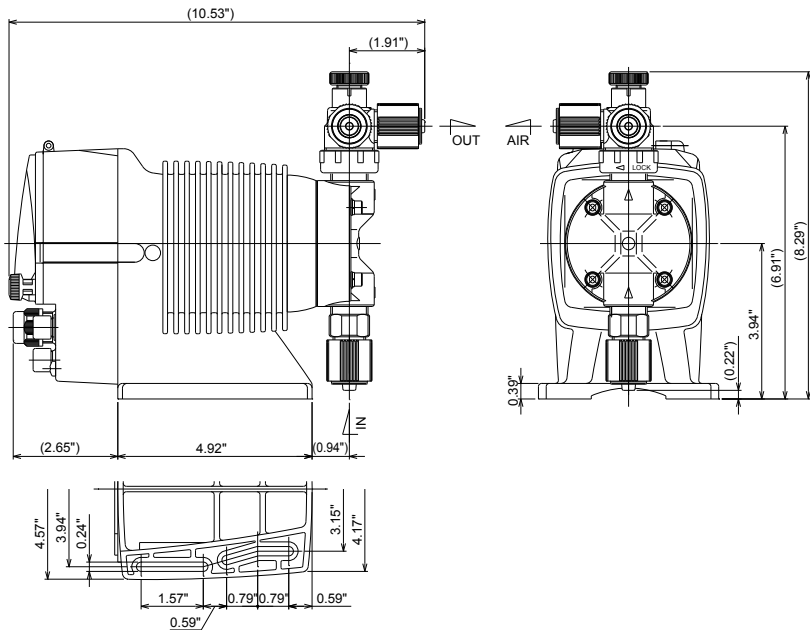



■ EWN-[B11•B16•B21] SH [U•U2]R

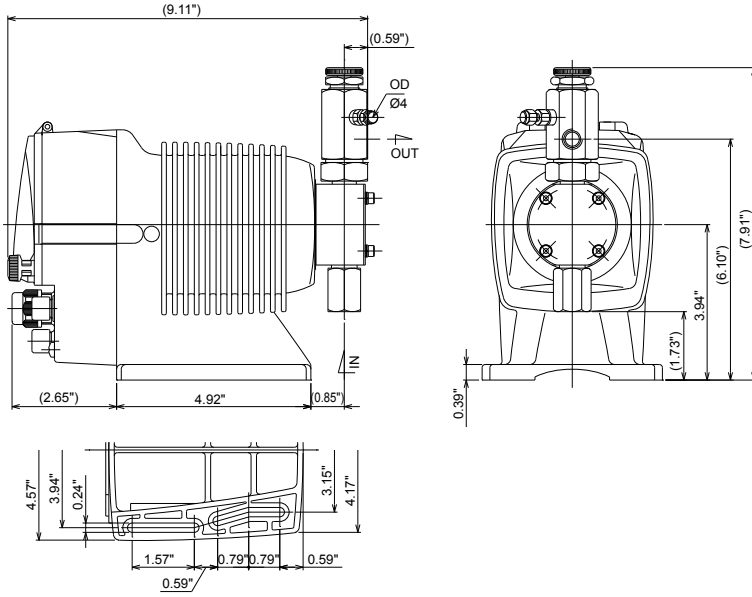

■ EWN-B31 SH [U•U2]R

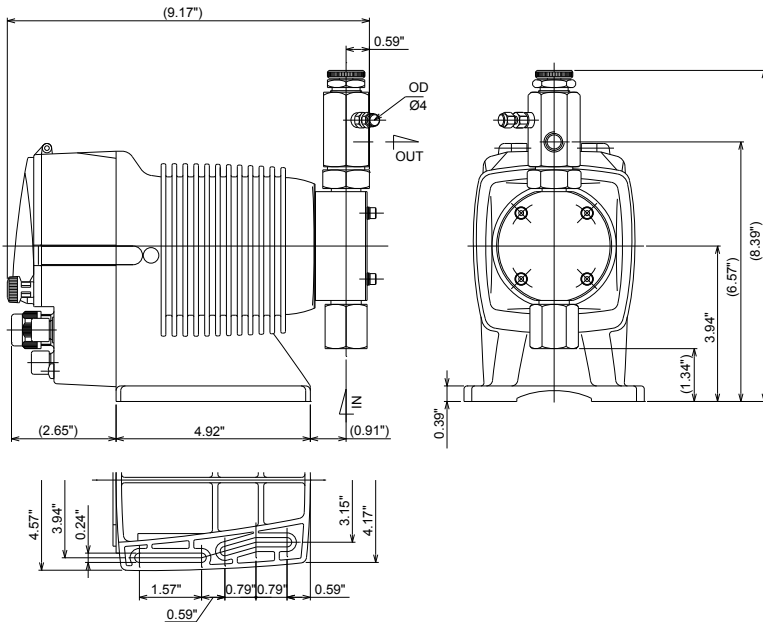

■ EWN-[C16•C21] SH [U•U2]R

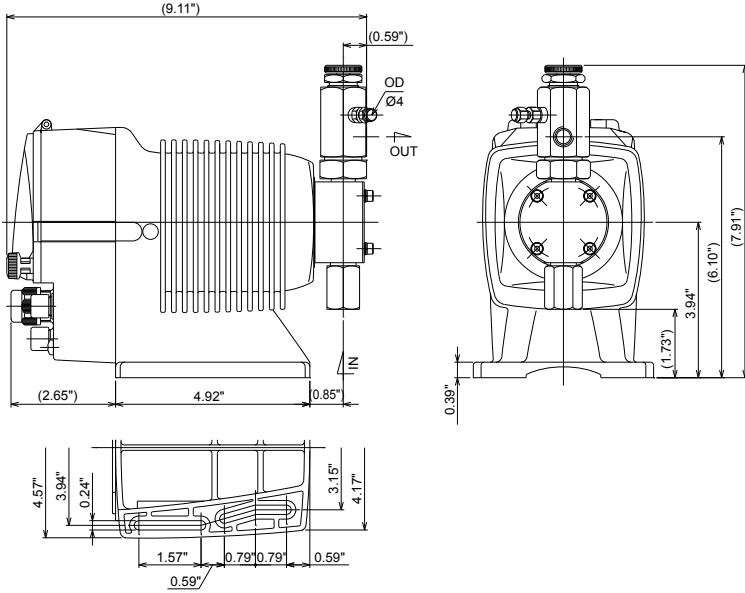

■ EWN-C31 SH [U•U2]R

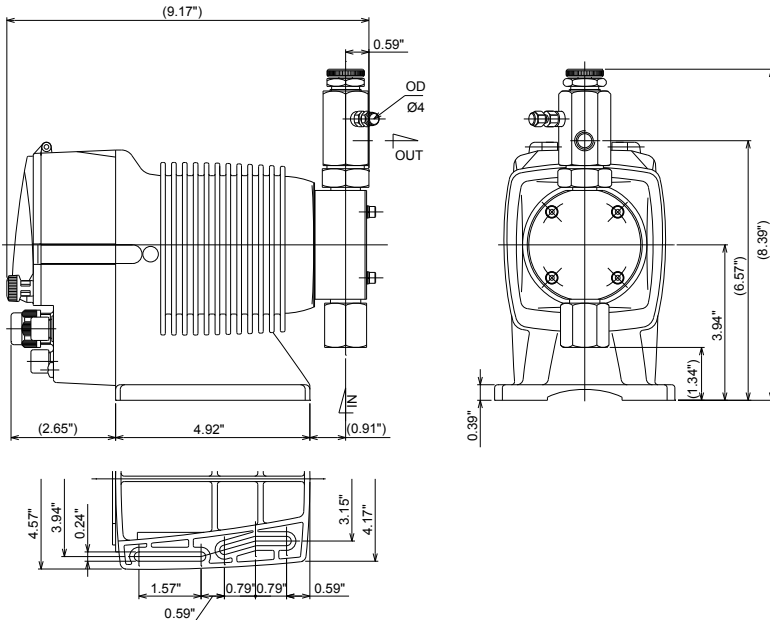

■ EWN-C36 SH [U·U2]R

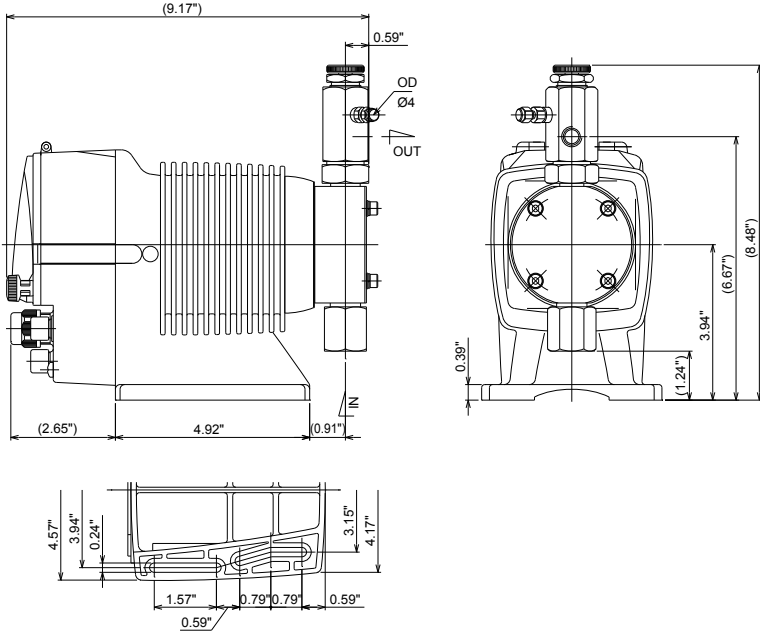

■ EWN-[B09·B11·B16·B21] [VC·VH·VE] [U·U2]RC (High compression type)

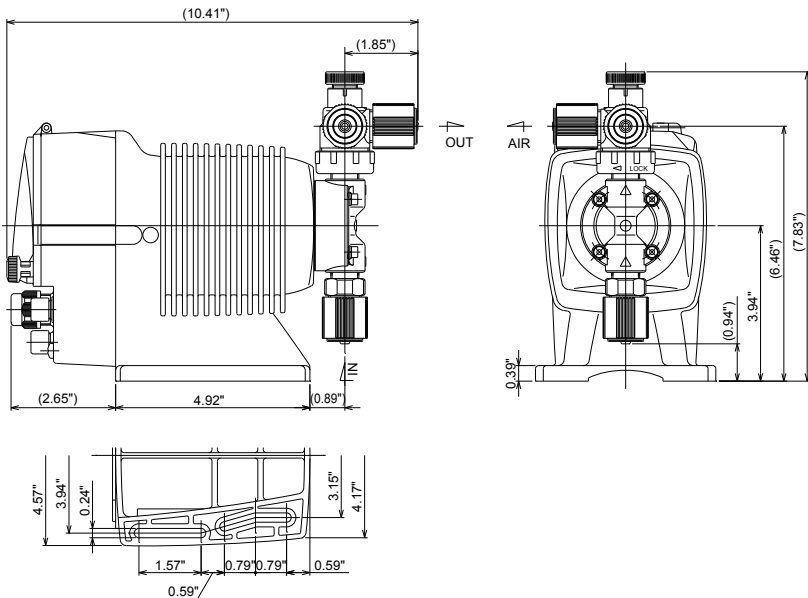

■ EWN-[C16•C21] [VC•VH•VE] [U•U2]RC (High compression type)

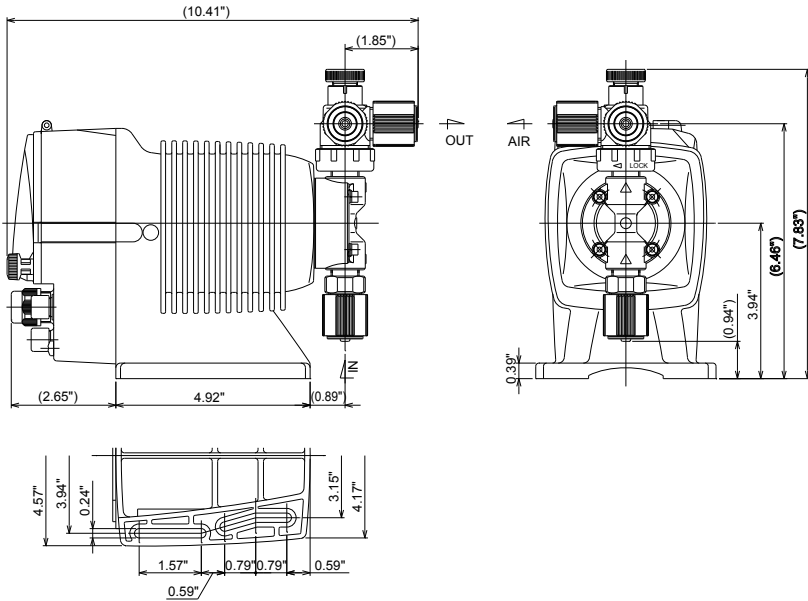

■ EWN-B11 [PC•PH] [U•U2]RH (High pressure type/High pressure type (2MPa))

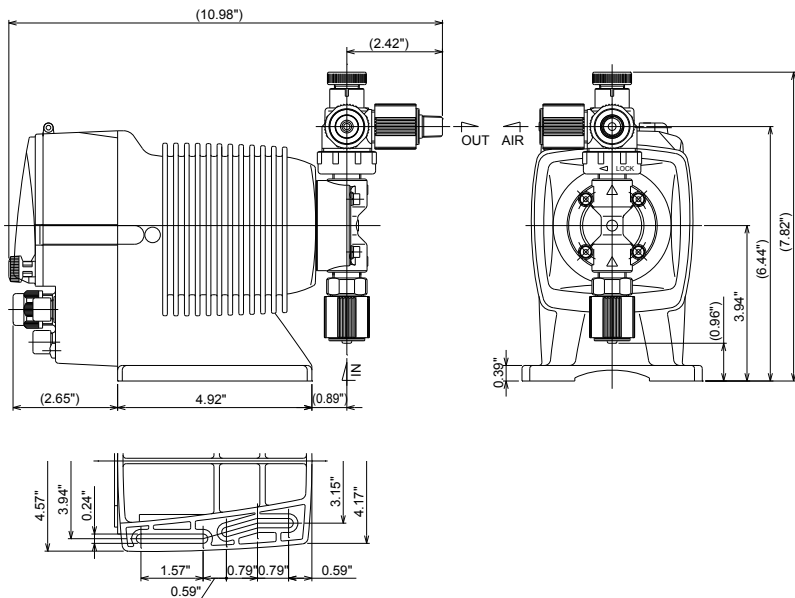

■ EWN-C16 [PC•PH] [U•U2]RH (High pressure type)

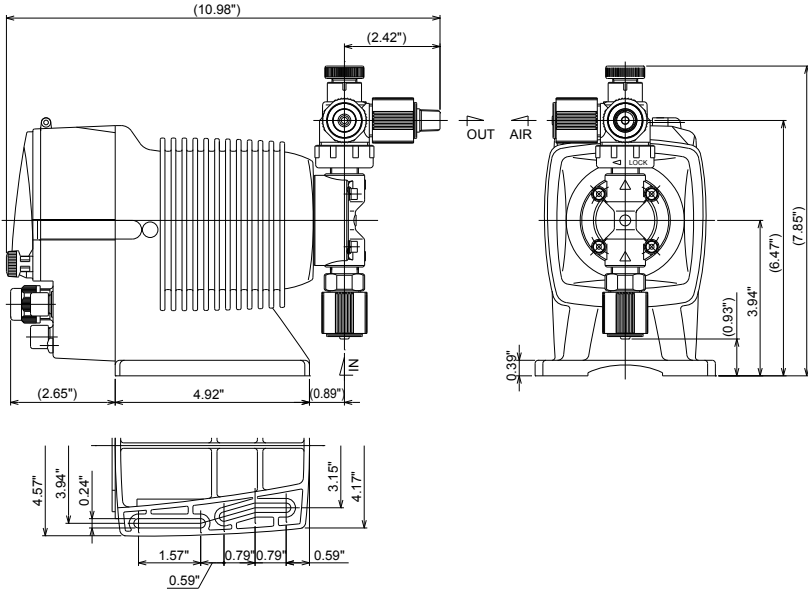

■ EWN-B11 SH [U•U2]RH (High pressure type/High pressure type (2MPa))

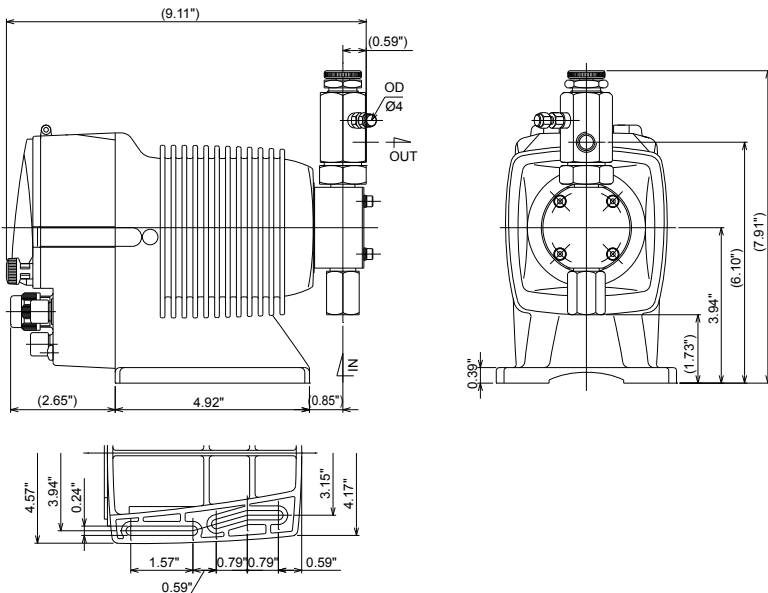

■ EWN-C16 SH [U·U2]RH (High pressure type)

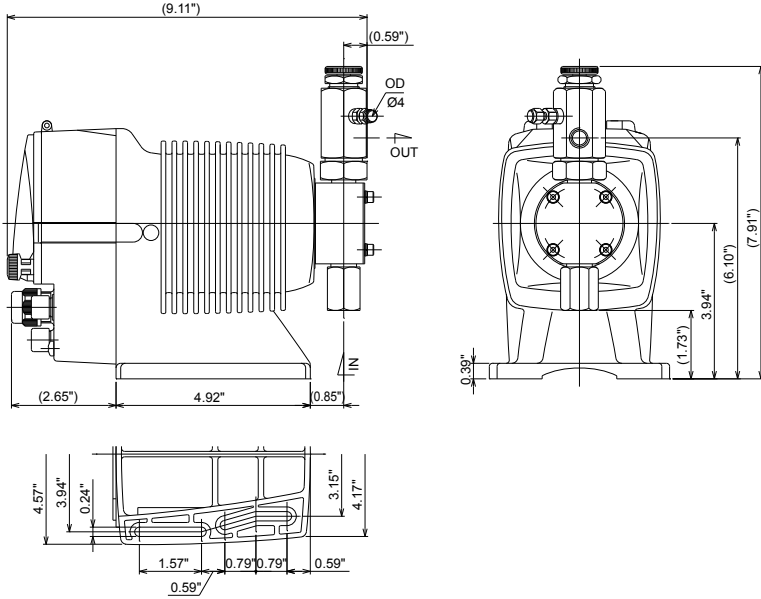

■ EWN-C31 [P6] [U·U2]RV (High viscosity type)

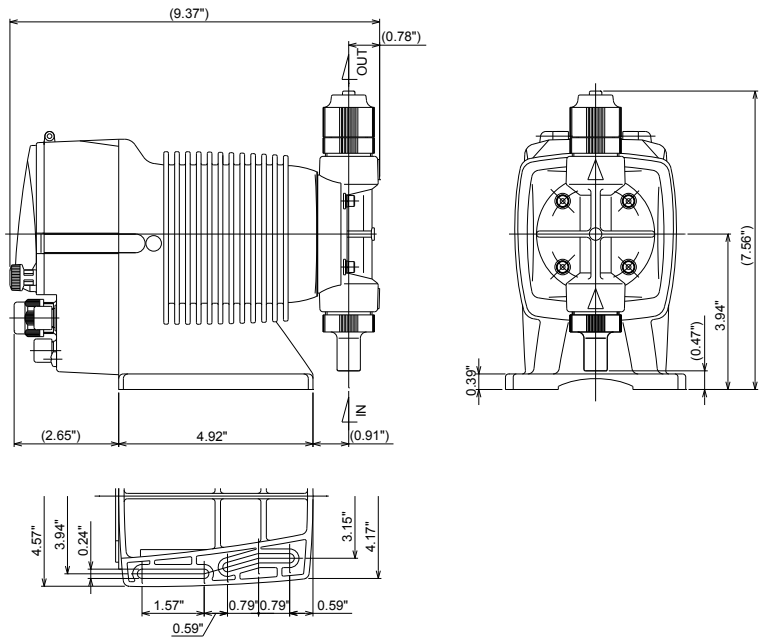

■ EWN-[B11•B16] (Auto degassing type)

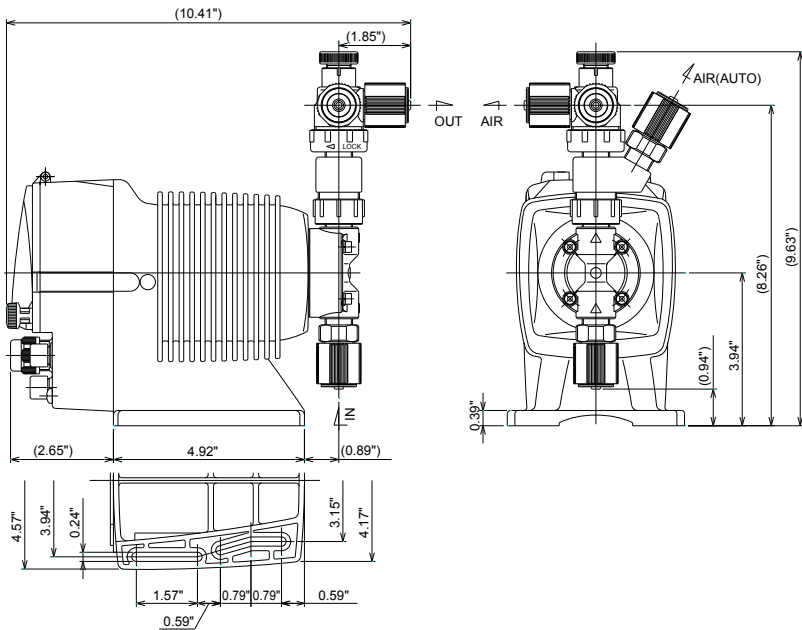

■ EWN-[C16•C21] (Auto degassing type)

